

أعلان رقم (ب- ٢٨) لسنة ٢٠١٧

تعلن شركة مصافي الوسط عن اعلان الطلبات الاستيرادية كما مبين أدناه :-

REQ.NO.	DESCRIPTION	QTY	ADVERTISEMENT NO.	BID BOND
1215/2017	VALVE & FITTING	10 ITEMS	TWICE	540 \$

وبالشروط التالية :-

- ١- سيتم بيع مواصفات الطلبية بمبلغ ٢٥٠٠٠٠ (مائتان وخمسون الف) دينار عراقي غير قابل للرد او تحويل ذلك المبلغ الى المصرف الخاص لشركتنا (مصرف الرافدين) الفرع الرئيسي ورقم الحساب هو ٩٠٩٥٦
- ٢- يتم فتح العروض الفنية والتجارية في ان واحد (في اليوم الذي يلي تاريخ الغلق) وفي حالة مصادفة عطلة توّجّل الى اليوم التالي وبالامكان حضور ممثلي الشركات الى مقر شركتنا عند الساعة العاشرة من اليوم الذي يلي تاريخ الغلق و المثبت في الفقرة (٢٨) ادناه
- ٣- يفضل تقديم الاسعار بعملة الدولار (CIP) واصل بغداد / شركة مصافي الوسط وتكون الاسعار نهائية وغير قابلة للتفاوض وشركتنا غير ملزمة بقبول أوطا الاسعار.
- ٤- سيتم تقديم عرضين مغلّقين (فني وتجاري) منفصلين مثبت عليهما رقم المناقصة وعنوانها وتاريخ الغلق وموقعين من قبل المدير العام أو المدير المفوض مع تثبيت الاسم الكامل وعليهما ختم الشركات في الصندوق الخاص في استعلامات شركتنا تقبل العروض التي ترسل مغلّفة بالبريد أو D.H.L وتهمل العروض التي ترد بعد تاريخ الغلق أو عن طريق البريد الالكتروني.
- ٥- يجب تحديد فترة نفاذية العرض ضمن العرض الفني وكذلك تثبيتها على الظرف الخاص بالعرض التجاري وكذلك تحديد تاريخ نفاذية التامينات الأولية في كلا العرضين ويجب ان لا تقل مدة نفاذ العروض عن (١٢٠ يوما).
- ٦- ترقيم كل صفحة من صفحات الطءاء(الفني والتجاري) مع المرفقات.
- ٧- على الشركات الراغبة في المشاركة تقديم كافة المستمسكات الاصولية والقانونية الخاصة بالشركة (شهادة تاسيسية حديثة وناظفة ومصدقة حسب الاصول من السفارة أو القنصلية العراقية في بلد الشركة – براءة ذمة صادرة من الهيئة العامة للضرائب تتضمن الرقم الضريبي – الموقف المالي متمثل بحسابات ختامية لآخر سنتين مالية – الهوية التجارية النافذة) مع تقديم الاعمال المماثلة صادرة من قبل جهات التعاقد المعنية قبل شراء الطلبية أو ترفق مع العرض الفني المقدم في حالة عدم تقديمها سابقاً
- ٨- يتم تقديم تامينات أولية وحسب المبالغ المثبتة امام كل طلبية في الاعلان اعلاه من قبل احد المساهمين في الشركة وحسب التعليمات وترفق مع العرض التجاري (خطاب ضمان او صك مصدق او سفتجة) نسخة اصلية صادرة من احد المصارف العراقية (مصرف الهدي ، البلاد الاسلامي للاستثمار والتمويل ، المصرف العراقي للتجارة ، مصرف كوردستان الدولي للاستثمار والتنمية ، مصرف اربيل ، مصرف جيهان للاستثمار والتمويل ، الوطني الاسلامي ، المنصور للاستثمار ، الاقليم التجاري للاستثمار والتمويل (اميرالد سابقا) ، مصرف بغداد ، مصرف الخليج التجاري ، سومر التجاري ، الائتمان العراقي ، الاهلي العراقي ، الاستثمار العراقي ، اشور الدولي للاستثمار ، العراقي الاسلامي للاستثمار والتنمية ، التتمية الدولي للاستثمار والتمويل ، التجاري العراقي ، مصرف بيبيلوس اللباني ، مصرف الشرق الاوسط العراقي للاستثمار ، البحر المتوسط ، مصرف التعاون الاسلامي للاستثمار) وكافة فروع المصارف الاجنبية العاملة في العراق وترفق مع العرض التجاري وتطلق هذه التامينات في حالة عدم احوالة الطلبية عليكم وتهمل العروض التي لم ترفق بها التامينات الأولية. ترفق التامينات الأولية الصادرة من (بنك اسيا التركي ، دار السلام للاستثمار ، مصرف الشمال ، مصرف دجلة والفرات للتنمية والاستثمار و مصرف الوركاء للاستثمار والتمويل ومصرف البصرة الدولي و المصرف المتحد للاستثمار ومصرف الاقتصاد للاستثمار و التمويل ومصرف الاتحاد العراقي ، مصرف الرواحل الاسلامي للاستثمار والتمويل) ويجب ان تكون هذه التامينات نافذة لمدة لا تقل عن (١٢٠) يوما (تهمل العروض اذا كانت التامينات الأولية على شكل سويفت) .
- ٩- تحديد فترة التجهيز بالايام ولا يجوز تثبيت عبارة (من – الى) .
- ١٠- شروط الدفع/ اعتماد مستندي غير مثبت وغير قابل للنقض أو التحويل تطلق المستحقات (١٠٠ %) بعد استلام المواد كاملة ومطابقة للمواصفات في مصفى الدورة و يمكن الاتفاق على نسب أخرى مقابل كفالته مصرفيه ضامنه يتم احتساب اسعار جميع العطاءات لاغراض المفاضلة على اسس موحد و بموجب نشرة البنك المركز العراقي يوم الفتح ويكون الدفع بالدينار العراقي فقط للشركات العراقية ويتم احتساب الاسعار على اساس نشرة البنك المركزي العراقي ليوم اعداد العقد ويثبت المبلغ في العقد
- ١١- تفرض غرامة تاخيرية على المجهز لا يتجاوز حدها الأعلى نسبة ١٠ % من مبلغ عقد في حالة عدم تجهيز المواد بفترة التجهيز المثبتة في العقد.
- ١٢- تقدم التامينات النهائية على شكل خطاب ضمان حسن تنفيذ (حصرا) للعقد بنسبة (٥%) خمسة من المنة من مبلغ العقد بعد التبليغ بكتاب الاحالة وقيل توقيع العقد ومن احد المصارف الواردة في الفقرة رقم ٨ خلال مدة لا تتجاوز (١٥) يوما" وكشرط لتفعيل الاعتماد وفي حالة التأخر، تهمل الاحالة ويحال المجهز إلى لجنة الناقلين. وتبقى الكفالة نافذة لمدة العقد او تمديده عند تمديد فترة التجهيز او لحين انتهاء فتره الضمان، في حاله وجود (فترة ضمان) تطلق كفالة حسن الاداء بعد استلام المواد كاملة ومطابقة للمواصفات وبعد انجاز المجهز كافة التزامات المنصوصه في العقد وبخلافه سيتم مصادرتها من قبل شركتنا .
- ١٣- سيتم استقطاع نسبة (٢,٧ %) من قيمة العقد كضريبة وذلك بالنسبة للشركات العراقية وايضا في حالة الدفع بالدينار العراقي اما في حالة الشركات الغير عراقية فيتم حجز هذه النسبة كإمانات ضريبية وتطلق بعد ان يقوم المجهز بترويدنا ببراءة ذمة من الهيئة العامة للضرائب وبخلافه سيتم إحالة هذه الامانات إلى الهيئة العامة للضرائب خلال مدة لا تزيد عن (٣٠) يوم من تاريخ انجاز العمل وتكون النسبة ٣ % للعقود المتضمنة نصب واشراف موقعي ولا يتم صرف الدفعة الاخيرة للمقاولين والمتعاقدين وعدم تسوية الحساب النهائي للمقاول الاموافقة تحريرية من الهيئة العامة للضرائب او استقطاع مانسبته (١٠%) عشرة من المنة منها وارسالها الى الهيئة العامة للضرائب قبل اطلاق الدفعة الاخيرة سواء اكان تنفيذ العقد على دفعة واحدة ام على عدة دفعات .
- ١٤- تستقطع نسبة (٠,٠٠٣) من مبلغ العقد كرسوم طابع .
- ١٥- يستقطع مبلغ (٢٥٥٠٠٠) دينار عراقي من مبلغ العقد عن قيمة اجازة الاستيراد.
- ١٦- شهادة المنشأ يجب ان تكون مصدقة من قبل الملحقية التجارية العراقية أو السفارة في بلد المنشأ .
- ١٧- سيتم استقطاع مبلغ الاجور البيئية بعد اصدار العقد بموجب ما يتم تحديده من قبل وزارة البيئة (للمواد الكيماوية حصرا)
- ١٨- لا يجوز لمقدم العطاء شطب أي بند من بنود مستندات المناقصة أو إجراء أي تعديل فيها مهما كان نوعه .
- ١٩- منشأ المواد ينبغي ان يحدد في العرض ويكون من ضمن المنشأء المطلوبة وثابت (لن يتغير لأي سبب كان) مع تحديد طريقة وميناء الشحن منفذ الدخول .
- ٢٠- يقوم المجهز بتثبيت عنوانه الكامل (الدولة – المدينة – الشارع – البناية – العنوان البريدي والهاتف) و اسم المدير العام للشركة أو من يخولهم في العروض والمراسلات وبشكل واضح ورسمي وبخلافه يهمل العرض .

٢١- تقديم شهادة فحص طرف ثالث من إحدى الشركات التالية :

[LLOYD'S REGISTER – BUREAU VERITAS - INTERTEK GLOBAL - TUV RHEINLAND - DNV]

- ٢٢- تقديم كتاب تحويل من الشركات المصنعة مصدقة من وزارة الخارجية او السفارة او القنصلية او الملحقة التجارية في بلد المنشأ (نسخة اصليّة) وحسب التعليمات لطلبية (تجهيز المواد المتخصصة) .
- ٢٣- يتحمل من ترسو عليه المناقصة أجور نشر الإعلان مقدارها (١٥٠ دولار)
- ٢٤- تطبيق القوانين والتعليمات المعمول بها في العراق في حالة وقوع منازعات أو في كل ما لم يرد به نص ويكون النزاع خاضعاً لولاية القضاء العراقي مع تطبيق قانون تحصيل الديون الحكومية رقم ٥٦ لسنة ١٩٧٧ بأن المستحقات المالية تترتب لشركتنا بذمة الطرف الآخر .
- ٢٥- في طلبية المواد الكيماوية يجب ان تقدم النماذج خلال فترة الغلق (مع العروض الفنية والتجارية) وبخلافه سيتم اهمال العروض .
- ٢٦- عدم تعامل الشركة المتعاقد معها مع اسرائيل بأي شكل من الاشكال ، وبخلافه تتحمل كافة التبعات القانونية .
- ٢٧- يتوجب على الشركات التي ترغب بالمشاركة في اي طلبية والتي تطلب اي معلومات فنية شراء الطلبية ويتم ارفاق وصل الشراء مع الرسالة وقيل مدة مناسبة من تاريخ الغلق وستقوم شركتنا بتحديد تاريخ انعقاد المؤتمر الخاص بالاجابة عن استفسارات المشتركين في المناقصة وقيل موعد لايقبل عن (٧) ايام من تاريخ غلق المناقصة .
- ٢٨- تاريخ الغلق الساعة (١) بعد الظهر ليوم ٢٨ / ٨ / ٢٠١٧ .
- ٢٩- كافة الاجراءات لطلبية الشراء خاضعة لتعليمات تنفيذ العقود الحكومية رقم (٢) لسنة ٢٠١٤ والضوابط والتعديلات .

ملاحظة يمكن الاطلاع على شروط تقديم العطاءات وعلى الموقع الالكتروني :- www.oil.gov.iq
www.mrc.oil.gov.iq

----- مع التقدير

زيد كاظم شريف
المدير العام/ وكالة

IT.	QTY	UNIT	VOCAB NO.	DESCRIPTION
				VALVE & FITTING
				PLUG VALVE MATERIAL (FORGED OR CAST CARBON STEEL) TO ASTM (A 105 OR 216 GR WCB), RATING (600 LBS, OR 800 LBS), TYPE (HYPER SEAL OR REGULAR PATTERN OR STANDARD), THE ENDS IS SCREWED FEMALE TO ANSI (B 1.20.1), COMPLETE WITH WRENCH OPERATED
1.	11	NOS	801841/109.2	SIZE 1/2"
2.	23	NOS	801841/111.2	SIZE 1"
3.	50	NOS	113.2	SIZE 1.1/2"
4.	44	NOS	114.2	SIZE 2"
				VALVE FLANGED WEDGE GATE (# 300 IBS) LARGE MALE. THE HEIGHT RAISED FACE (R. F) NO OF LARGE MALE (R. F = 1/4") ACCORDING TO FLANGE FACING TO ASME / ANSI (B 16.5), MATERIAL CAST CARBON STEEL BODY TO ASTM (A 216 GR WCB), OUTSIDE SCREW & YOKE BOLTED BONNET, RISING STEM, TRIM (11.1/2 - 13%CHR) FLANGED DRILLED TO ANSI (B 16.5)
5.	6	NOS	801854/257.2	SIZE 2.1/2"
6.	6	NOS	258.2	SIZE 3"
				SINGLE -PLATE WAFER -TYPE CHECK VALVE, SHORT PATTERN CLASS #150 LBS, BODY MATERIAL (CAST OR FORGING) CARBON STEEL ACCORDING TO ASTM (A 216 GR WCB OR A 105), DISC MATERIAL STAINLESS -STEEL TYPE (304 OR 316 OR 321 OR 410,...) TRIM(11-13%CHR), DESIGN & MANUFACTURE CONFORMING TO (API 6D), FACE TO FACE DIMENSION CONFORMING TO (API 6D) FLANGE DIMENSION CONFORMING TO ANSI (B 16.5), PRESSURE & TEMPERATURE RATING CONFORMING TO ANSI (B 16.34), TESTED & INSPECTION ACCORDING TO (API 598)
7.	63	NOS	801901/210.2	4"
				Y STRAINER FLANGE RATING # 150 LBS MATERIAL TO ASTM (A216 GR WCB), THE FLANGE TO ANSI (B 16.5)
8.	2	NOS	801910/206.3	2"
				Y STRAINER FLANGED TYPE MATERIAL CAST CARBON STEEL BODY CONFORMING TO ASTM (A216 WCB)
9.	2	NOS	801910/214.2	10" X #150
				STRAINER FLANGED MATERIAL CAST STEEL ACCORDING TO ASTM A216 WCB SCH 20
10.	2	NOS	801910/215.2	12" X #150

ORIGIN : EUROPEAN – USA – JAPAN – SOUTH KOREA

1- CERTIFICATE OF ORIGIN

2- MILL CERTIFICATE

3- DIMENSIONS CHECK

4- THIRD PARTY INSPECTION

1-DIMENSIONS CHECK APPROVAL

2- MILL CERTIFICATE APPROVAL

3- HYDROSTATIC TEST APPROVAL

LLOYDS REGISTER

BUREAU VERITAS

TUV RHENLAND

INTERTEK GLOBAL

DNV

-the cost of third party inspection shall be 1% of total cost of the contract

-the third party inspection shall be spot witness for the following 10% activities (minimum of tests):-

-chemical analysis.

-Dimension check

-Hydrostatic test

-the other inspection activities according to (ASTM) standard shall be reviewed by third party inspection.

DELIVERY PERIODE (60 DAYS)

ADVERTISEMENT
MIDLAND REFINERIES CO. ANNOUNCES FOR PURCHASING THE MATERIALS AS STATED BELOW:-

REQ.NO.	DESCRIPTION	QTY	ADVERTISEMENT NO.	BID BOND
1215/2017	VALVE & FITTING	10 ITEMS	TWICE	540 \$

1-The requisition to be sold in (250, 000) Iraqi dinars; un returnable or to transfer this amount to MRC Bank account number (90956)in Rafidan Bank head branch .

2-Technical and commercial offer should be opened at the same time, the representatives of the companies can be attend to our company (MRC) at 10 o'clock morning one day after the closing day stated below in item (28) .

3-Offered prices should be (CIP) Baghdad / Daura Refinery and preferred to be in us dollar. they will be final and nonnegotiable . (MRC) is not obliged to accept the lowest prices.

4-offeres (TECHNICAL & COMMERCIAL) to be submitted, separately in sealed envelopes, either directly at (MRC) reception bureau or sent by (DHL). the requisition number, the description and the closing date should be fixed on both envelopes. the validity of the offer should be mentioned within the technical offer ; also on the envelope of the commercial offer. offers sent by e- mail will be neglected.

5- The validity of the bid bond and the offer should be mentioned within both offers and should not be less than (120) days.

6- All pages of, both, the technical and commercial offers should be numbered in sequence, including the attachments and documents.

7-All documents (profile) (new establishment certificate stamped from the Iraqi embassy in your country financial statement accounts for the last two year (balance sheet) exemption letter issued from general commission for tax contain the taxes number and similar contracts achieved, issued by concerned contracting sides enclosed with the technical offer before purchasing the requisition.

8- A BID BOND OF AMOUNT THAT STATED IN THE ADVERTISEMENT ABOVE AGAINST EACH TENDER SHOULD BE SUBMITTED WITH COMMERCIAL OFFER FROM ONE OF THE PARTICIPANT IN THE COMPANY ACCORDING TO INSTRUCTION AS(LETTER OF GUARANTEE , CERTIFIED CHEQUE OR BILL OF EXCHANGE) (ORIGINAL COPY), ISSUED FROM :((HUDA BANK , ALBILAD ISLAMIC BANK FOR INVESTMENT AND FINANCE , TRADE BANK OF IRAQ , KURDISTAN INTERNATIONAL BANK FOR INVESTMENT AND DEVELOPMENT , ERBIL BANK , CIHAN BANK FOR ISLAMIC INVESTMENT AND FINANCE , NATIONAL ISLAMIC BANK , MANSOUR BANK FOR INVESTMENT , REGION FOR BUSINESS INVESTMENT AND FINANCING (EMERALD BANK BEFORE), BANK OF BAGHDAD , GULF COMMERCIAL BANK, SUMER COMMERCIAL BANK , CREDIT BANK OF IRAQ , NATIONAL BANK OF IRAQ , INVESTMENT BANK OF IRAQ , ASHUR INTERNATIONAL BANK FOR INVESTMENT , IRAQI ISLAMIC BANK FOR INVESTMENT AND DEVELOPMENT , INTERNATIONAL DEVELOPMENT BANK INVESTMENT AND FINANCE , COMMERCIAL BANK OF IRAQ , BYBLOS BANK , IRAQ IMDLEST BANK OF INVESTMENT , BANK MED , ISLAMIC REGIONAL COOPERATION BANK FOR DEVELOPMENT AND INVESTMENT)) AND RELEASED IMMEDIATELY IN CASE THE REQUISITION IS NOT AWARDED. OFFERS WITHOUT BID BOND WILL BE NEGLECTED . BID BOND ISSUED FROM ((ASIA BANK , DAR ESSALAAM INVESTMENT BANK , NORTH BANK FOR FINANCIAL AND INVESTMENT , DIJLAH AND FURAT BANK , WARKA BANK FOR INVESTMENT & FINANCE , THE BANK OF BASRAH INTERNATIONAL , UNITED BANK FOR INVESTMENT , ECONOMY FOR INVESTMENT AND FINANCE , UNION BANK OF IRAQ , ALRAWAHEL ISLAMIC INVESTMENT AND FINANCE BANK)) ARE NOT ACCEPTABLE . THIS BID BOND SHOULD BE VALID FOR NOT LESS THAN (120) DAYS (OFFERS WHICH CONTAIN BID BOND AS A SWIFT WILL BE NEGLECTED).

9- the delivery period (in days) should be, exactly specified.

10- Basic terms of payment is by irrevocable & unconfirmed letter of credit to be paid (100%) after the receipt of goods in baghdad complete and as ordered. other terms of payment may be, mutually, agreed upon later and for certain conditions, which are : a portion of the total amount to be paid, but against bank guarantee the prices of all offers are calculated according to the exchange rate of the central bank of iraq .at the date of opening the offers .for the purpose of preferability and by iraqi dinar only , for iraqi companies according to the exchange rate of the central bank of iraq at the date of preparing the contract,and the cost was stated in the contract.

11- Delay penalty to be applied with total amount, not exceeding (10%) of the total value of the contract .

12- An unconditional performance bond of (5%) of the total value of the contract to be submitted, from one of the participant in the company as a letter of guarantee (only) after the letter of award and before signing the contract according to instruction , from one of the banks mentioned in item (8) within (15) fifteen days from the date, the supplier is informed of the award. for any delay beyond the specified period, the award will be cancelled and the supplier will be considered as a shirker. the performance bond should be valid throughout the period of the contract or extending it upon extending the period of supply or until the guarantee period (if stated), is over. this performance bond will be released after the receipt of goods complete and as ordered and the supplier has fulfilled all his commitments regarding the contract otherwise, it will be confiscated by our company

13- (2.7%) of the total value of the contract to be deducted as taxes for iraqi companies. also, in case the payment is in iraqi dinar. for non-iraqi companies, the deducted amounts shall be transferred to the general commission of taxes within a period not exceeding (30) days from the date of completing the work and 3% for the contract contain onsite training , installation and operation not to pay the final payment to the second party and not to settle the final account unless after a written approval issued by the general commission for taxes, or deducting a percentage of 10% from it and sent it to the general commission for taxes before the release the final payment , whether the contract execution is in one payment or in multiple payments .

14- (0.003) off the total value of the contract to be deducted as stamp charges.

15- A sum of (205,000.00) id to be deducted as cost of import license.

16- Origin certificate should be approved by iraqi embassy/commercial attaché in the country of origin.

17- a sum of money in Iraqi dinar for chemical materials to be deducted as an environmental cost after issuing the contract & will be determined by ministry of environment (for chemical materials only).

- 18- The participant has no right to omit or make any amendment, whatsoever, to any of the paragraphs of the requisition document.
- 19- The origin of the materials should be specified in the offer and fixed. and will not be changed for any reason and should be from the requested origin . State the method & the port of shipment & the entry point .
- 20- The supplier should state his full and fixed name and address
(Country , City , Street, Building, Email ,Phone NO.)
ALL offers and correspondences should be, clearly, signed by the general manager or whom is officially empowered via power of attorney. otherwise the offer will be neglected.
- 21- Third party inspection certificate should be provided from one of the following companies:
[LLOYDS REGISTER – BUREAU VERITAS - INTERTEK GLOBAL - TUV RHEINLAND - DNV]
- 22- It is necessary to present authorization letter from the manufacturer companies certified from ministry of foreign affairs or embassy or consulate or the commercial attached in country of origin (original copy)
(for tenders of specific materials)
- 23- The awarded supplier will bear the advertising fees value (150 \$) .
- 24- Iraqi laws are applied : the tender and the contract shall be governed and construed according to the iraqi law. courts shall have the exclusive jurisdiction to hear and determine all actions and proceedings arising out of the contract. governmental debts collection law (no. : 56), for the year 1977 shall be applied on amounts owed to (MRC).
- 25- For chemical (Req) the sample should be submitted with the technical & commercial offers before or (during)the closing otherwise the offers will be neglected
- 26- The contracted company shall not deal with Israel in any way ; otherwise , it shall bear all the legal consequences .
- 27-The companies that need any additional information in order to participate in any tender should buy the tender document & attached with their letters before closing date & our company shall state a date of conference for answering all questions in time not less than (7 day) before closing date
- 28- Closing date: 28 / 8 / 2017, till (1.00) o'clock (afternoon).**
- 29- All the procedure of the requirements governed by implementing Instructions of government contract No.2 for the Year 2014 , regulations and its amendments
Note: you can find the conditions of submitting offers on website: www.oil.gov.iq - www.mrc.oil.gov.iq

G. MANAGER

IT.	QTY	UNIT	VOCAB NO.	DESCRIPTION
				VALVE & FITTING
				PLUG VALVE MATERIAL (FORGED OR CAST CARBON STEEL) TO ASTM (A 105 OR 216 GR WCB), RATING (600 LBS, OR 800 LBS), TYPE (HYPER SEAL OR REGULAR PATTERN OR STANDARD), THE ENDS IS SCREWED FEMALE TO ANSI (B 1.20.1), COMPLETE WITH WRENCH OPERATED
1.	11	NOS	801841/109.2	SIZE 1/2"
2.	23	NOS	801841/111.2	SIZE 1"
3.	50	NOS	113.2	SIZE 1.1/2"
4.	44	NOS	114.2	SIZE 2"
				VALVE FLANGED WEDGE GATE (# 300 IBS) LARGE MALE. THE HEIGHT RAISED FACE (R. F) NO OF LARGE MALE (R. F = 1/4") ACCORDING TO FLANGE FACING TO ASME / ANSI (B 16.5), MATERIAL CAST CARBON STEEL BODY TO ASTM (A 216 GR WCB), OUTSIDE SCREW & YOKE BOLTED BONNET, RISING STEM, TRIM (11.1/2 - 13%CHR) FLANGED DRILLED TO ANSI (B 16.5)
5.	6	NOS	801854/257.2	SIZE 2.1/2"
6.	6	NOS	258.2	SIZE 3"
				SINGLE -PLATE WAFER -TYPE CHECK VALVE, SHORT PATTERN CLASS #150 LBS, BODY MATERIAL (CAST OR FORGING) CARBON STEEL ACCORDING TO ASTM (A 216 GR WCB OR A 105), DISC MATERIAL STAINLESS -STEEL TYPE (304 OR 316 OR 321 OR 410,...) TRIM(11-13%CHR), DESIGN & MANUFACTURE CONFORMING TO (API 6D), FACE TO FACE DIMENSION CONFORMING TO (API 6D) FLANGE DIMENSION CONFORMING TO ANSI (B 16.5), PRESSURE & TEMPERATURE RATING CONFORMING TO ANSI (B 16.34), TESTED & INSPECTION ACCORDING TO (API 598)
7.	63	NOS	801901/210.2	4"
				Y STRAINER FLANGE RATING # 150 LBS MATERIAL TO ASTM (A216 GR WCB), THE FLANGE TO ANSI (B 16.5)
8.	2	NOS	801910/206.3	2"
				Y STRAINER FLANGED TYPE MATERIAL CAST CARBON STEEL BODY CONFORMING TO ASTM (A216 WCB)
9.	2	NOS	801910/214.2	10" X #150
				STRAINER FLANGED MATERIAL CAST STEEL ACCORDING TO ASTM A216 WCB SCH 20
10.	2	NOS	801910/215.2	12" X #150

ORIGIN : EUROPEAN – USA – JAPAN – SOUTH KOREA

1- CERTIFICATE OF ORIGIN

2- MILL CERTIFICATE

3- DIMENSIONS CHECK

4- THIRD PARTY INSPECTION

1-DIMENSIONS CHECK APPROVAL

2- MILL CERTIFICATE APPROVAL

3- HYDROSTATIC TEST APPROVAL

LLOYDS REGISTER

BUREAU VERITAS

TUV RHENLAND

INTERTEK GLOBAL

DNV

-the cost of third party inspection shall be 1% of total cost of the contract

-the third party inspection shall be spot witness for the following 10% activities (minimum of tests):-

-chemical analysis.

-Dimension check

-Hydrostatic test

-the other inspection activities according to (ASTM) standard shall be reviewed by third party inspection.

DELIVERY PERIODE (60 DAYS)

أعلان رقم (ب- ٢٨) لسنة ٢٠١٧

تعلن شركة مصافي الوسط عن اعلان الطلبات الاستيرادية كما ميين أدناه :-

REQ.NO.	DESCRIPTION	QTY	ADVERTISEMENT NO.	BID BOND
1220/2017	METALS	22 ITEMS	TWICE	1800 \$

وبالشروط التالية :-

- ١- يتم بيع مواصفات الطلبية بمبلغ ٢٥٠٠٠٠ (مائتان وخمسون الف) دينار عراقي غير قابل للرد او تحويل ذلك المبلغ الى المصرف الخاص لشركتنا (مصرف الرافدين) الفرع الرئيسي ورقم الحساب هو ٩٠٩٥٦
- ٢- يتم فتح العروض الفنية والتجارية في ان واحد (في اليوم الذي يلي تاريخ الغلق) وفي حالة مصادفة عطلة توّجّل الى اليوم التالي وبالامكان حضور ممثلي الشركات الى مقر شركتنا عند الساعة العاشرة من اليوم الذي يلي تاريخ الغلق و المثبت في الفقرة (٢٨) ادناه
- ٣- يفضل تقديم الاسعار بعملة الدولار (CIP) واصل بغداد / شركة مصافي الوسط وتكون الاسعار نهائية وغير قابلة للتفاوض وشركتنا غير ملزمة بقبول أو طأ الاسعار.
- ٤- يتم تقديم عرضين مغلّقين (فني وتجاري) منفصلين مثبت عليهما رقم المناقصة وعنوانها وتاريخ الغلق وموقعين من قبل المدير العام أو المدير المفوض مع تثبيت الاسم الكامل وعليهما ختم الشركات في الصندوق الخاص في استعلامات شركتنا تقبل العروض التي ترسل مغلّفة بالبريد أو D.H.L وتهمل العروض التي ترد بعد تاريخ الغلق أو عن طريق البريد الالكتروني.
- ٥- يجب تحديد فترة نفاذية العرض ضمن العرض الفني وكذلك توثيقها على الظرف الخاص بالعرض التجاري وكذلك تحديد تاريخ نفاذية التأمينات الأولية في كلا العرضين ويجب ان لا تقل مدة نفاذ العروض عن (١٢٠ يوما).
- ٦- ترقيم كل صفحة من صفحات الطء (الفني والتجاري) مع المرفقات.
- ٧- على الشركات الراغبة في المشاركة تقديم كافة المستمسكات الاصولية والقانونية الخاصة بالشركة (شهادة تاسيسية حديثة ونافذة ومصدقة حسب الاصول من السفارة أو القنصلية العراقية في بلد الشركة – براءة ذمة صادرة من الهيئة العامة للضرائب تتضمن الرقم الضريبي – الموقف المالي متمثل بحسابات ختامية لآخر سنتين مالية – الهوية التجارية النافذة) مع تقديم الاعمال المماثلة صادرة من قبل جهات التعاقد المعنية قبل شراء الطلبية أو ترفق مع العرض الفني المقدم في حالة عدم تقديمها سابقاً
- ٨- يتم تقديم تأمينات أولية وحسب المبالغ المثبتة امام كل طلبية في الاعلان اعلاه من قبل احد المساهمين في الشركة وحسب التعليمات وترفق مع العرض التجاري (خطاب ضمان او صك مصدق او سفتجة) نسخة اصلية صادرة من احد المصارف العراقية (مصرف الهدي ، البلاد الاسلامي للاستثمار والتمويل ، المصرف العراقي للتجارة ، مصرف كوردستان الدولي للاستثمار والتنمية ، مصرف اربيل ، مصرف جيهان للاستثمار والتمويل ، الوطني الاسلامي ، المنصور للاستثمار ، الاقليم التجاري للاستثمار والتمويل (اميرالد سابقا) ، مصرف بغداد ، مصرف الخليج التجاري ، سومر التجاري ، الائتمان العراقي ، الاهلي العراقي ، الاستثمار العراقي ، اشور الدولي للاستثمار ، العراقي الاسلامي للاستثمار والتنمية ، التنمية الدولي للاستثمار والتمويل ، التجاري العراقي ، مصرف بيبيلوس اللباني ، مصرف الشرق الاوسط العراقي للاستثمار ، البحر المتوسط ، مصرف التعاون الاسلامي للاستثمار) وكافة فروع المصارف الاجنبية العاملة في العراق وترفق مع العرض التجاري وتطلق هذه التأمينات في حالة عدم احوالة الطلبية عليكم وتهمل العروض التي لم ترفق بها التأمينات الأولية. ترفض التأمينات الأولية الصادرة من (بنك اسيا التركي ، دار السلام للاستثمار ، مصرف الشمال ، مصرف دجلة والفرات للتنمية والاستثمار و مصرف النوراء للاستثمار والتمويل ومصرف البصرة الدولي و المصرف المتحد للاستثمار ومصرف الاقتصاد للاستثمار و التمويل ومصرف الاتحاد العراقي ، مصرف الرواحل الاسلامي للاستثمار والتمويل) ويجب ان تكون هذه التأمينات نافذة لمدة لا تقل عن (١٢٠) يوما (تهمل العروض اذا كانت التأمينات الأولية على شكل سويفت) .
- ٩- تحديد فترة التجهيز بالايام ولا يجوز تثبيت عبارة (من – الى) .
- ١٠- شروط الدفع/ اعتماد مستندي غير مثبت وغير قابل للنقض أو التحويل تطلق المستحقات (١٠٠ %) بعد استلام المواد كاملة ومطابقة للمواصفات في مصفى الدورة و يمكن الاتفاق على نسب أخرى مقابل كفاله مصرفيه ضامنه يتم احتساب اسعار جميع العطاءات لاغراض المفاضله على اسس موحد و بموجب نشرة البنك المركز العراقي يوم الفتح ويكون الدفع بالدينار العراقي فقط للشركات العراقية ويتم احتساب الاسعار على اساس نشرة البنك المركزي العراقي ليوم اعداد العقد ويثبت المبلغ في العقد
- ١١- ترفض غرامة تاخيرية على المجهز لايتجاوز حدها الاعلى نسبة ١٠ % من مبلغ عقد في حالة عدم تجهيز المواد بفترة التجهيز المثبتة في العقد.
- ١٢- تقدم التأمينات النهائية على شكل خطاب ضمان حسن تنفيذ (حصرا) للعقد بنسبة (٥%) خمسة من المئة من مبلغ العقد بعد التبليغ بكتاب الاحالة وقيل توقيع العقد ومن احد المصارف الواردة في الفقرة رقم ٨ خلال مدة لا تتجاوز (١٥) يوما" وكشرط لتفعيل الاعتماد وفي حالة التأخر، تهمل الاحالة ويحال المجهز إلى لجنة الناقلين. وتبقى الكفالة نافذة لمدة العقد او تمديده عند تمديد فترة التجهيز او لحين انتهاء فتره الضمان، في حاله وجود (فترة ضمان) تطلق كفالة حسن الاداء بعد استلام المواد كاملة ومطابقة للمواصفات وبعد انجاز المجهز كافة التزامات المنصوصه في العقد وبخلافه سيتم مصادرتها من قبل شركتنا .
- ١٣- سيتم استقطاع نسبة (٢,٧ %) من قيمة العقد كضريبة وذلك بالنسبة للشركات العراقية وايضا في حالة الدفع بالدينار العراقي اما في حالة الشركات الغير عراقية فيتم حجز هذه النسبة كامانات ضريبية وتطلق بعد ان يقوم المجهز بتزويدنا ببراءة ذمة من الهيئة العامة للضرائب وبخلافه سيتم إحالة هذه الامانات إلى الهيئة العامة للضرائب خلال مدة لا تزيد عن (٣٠) يوم من تاريخ انجاز العمل وتكون النسبة ٣ % للعقود المتضمنة نصب واشراف موقعي ولايتم صرف الدفعة الاخيرة للمقاولين والمتعاقدين وعدم تسوية الحساب النهائي للمقاول الاموافقة تحريرية من الهيئة العامة للضرائب او استقطاع ما نسبته (١٠%) عشرة من المئة منها وارسالها الى الهيئة العامة للضرائب قبل اطلاق الدفعة الاخيرة سواء اكان تنفيذ العقد على دفعة واحدة ام على عدة دفعات .
- ١٤- تستقطع نسبة (٠,٠٠٣) من مبلغ العقد كرسوم طابع .
- ١٥- يستقطع مبلغ (٢٥٥٠٠٠) دينار عراقي من مبلغ العقد عن قيمة اجازة الاستيراد.
- ١٦- شهادة المنشأ يجب ان تكون مصدقة من قبل الملحقية التجارية العراقية أو السفارة في بلد المنشأ .
- ١٧- سيتم استقطاع مبلغ الاجور البيئية بعد اصدار العقد بموجب ما يتم تحديده من قبل وزارة البيئة (للمواد الكيماوية حصرا)
- ١٨- لا يجوز لمقدم العطاء شطب أي بند من بنود مستندات المناقصة أو إجراء أي تعديل فيها مهما كان نوعه .
- ١٩- منشأ المواد ينبغي ان يحدد في العرض ويكون من ضمن المنشأ المطلوبة وثابت (لن يتغير لأي سبب كان) مع تحديد طريقة وميناء الشحن منفذ الدخول .
- ٢٠- يقوم المجهز بتثبيت عنوانه الكامل (الدولة – المدينة – الشارع – البناية – العنوان البريدي والهاتف)و اسم المدير العام للشركة أو من يخولهم في العروض والمراسلات وبشكل واضح ورسمي وبخلافه يهمل العرض .

٢١- تقديم شهادة فحص طرف ثالث من إحدى الشركات التالية :

[LLOYD'S REGISTER – BUREAU VERITAS - INTERTEK GLOBAL - TUV RHEINLAND - DNV]

- ٢٢- تقديم كتاب تحويل من الشركات المصنعة مصدقة من وزارة الخارجية او السفارة او القنصلية او الملحقة التجارية في بلد المنشأ (نسخة اصليّة) وحسب التعليمات لطلبية (تجهيز المواد المتخصصة) .
- ٢٣- يتحمل من ترسو عليه المناقصة أجور نشر الإعلان مقدارها (١٥٠ دولار)
- ٢٤- تطبيق القوانين والتعليمات المعمول بها في العراق في حالة وقوع منازعات أو في كل ما لم يرد به نص ويكون النزاع خاضعاً لولاية القضاء العراقي مع تطبيق قانون تحصيل الديون الحكومية رقم ٥٦ لسنة ١٩٧٧ بأن المستحقات المالية تترتب لشركتنا بذمة الطرف الآخر .
- ٢٥- في طلبية المواد الكيماوية يجب ان تقدم النماذج خلال فترة الغلق (مع العروض الفنية والتجارية) وبخلافه سيتم اهمال العروض .
- ٢٦- عدم تعامل الشركة المتعاقد معها مع اسرائيل بأي شكل من الاشكال ، وبخلافه تتحمل كافة التبعات القانونية .
- ٢٧- يتوجب على الشركات التي ترغب بالمشاركة في اي طلبية والتي تطلب اي معلومات فنية شراء الطلبية ويتم ارفاق وصل الشراء مع الرسالة وقيل مدة مناسبة من تاريخ الغلق وستقوم شركتنا بتحديد تاريخ انعقاد المؤتمر الخاص بالاجابة عن استفسارات المشتركين في المناقصة وقيل موعد لايقبل عن (٧) ايام من تاريخ غلق المناقصة .
- ٢٨- تاريخ الغلق الساعة (١) بعد الظهر ليوم ٢٨ / ٨ / ٢٠١٧ .
- ٢٩- كافة الاجراءات لطلبية الشراء خاضعة لتعليمات تنفيذ العقود الحكومية رقم (٢) لسنة ٢٠١٤ والضوابط والتعديلات .

ملاحظة يمكن الاطلاع على شروط تقديم العطاءات وعلى الموقع الالكتروني :- www.oil.gov.iq
www.mrc.oil.gov.iq

----- مع التقدير

زيد كاظم شريف
المدير العام/ وكالة

REQ.NO. – 1220 /2017

IT.	QTY	UNIT	VOCAB NO.	DESCRIPTIN
				METALS
				Aluminum alloy bar Astm B-211 alloy (1060): min .AL %99.6. round bar cross section :cold finished , yield strength tests are required length 25 CM
1.	280	CM	200105/048.2	3"X25 CM
2.	310	CM	200105/064.2	4" X25 CM
				Aluminum bronze rod conforming to Astm B-150 -82: copper alloy UNS No.(C63200): strength classification (HR 50) hot rolled and annealed Certificate is required. Colour identification: silver Inches mm in random lengths
3.	180	CM	200205/044.2	2.3/4" 70mm 60-90 CM
4.	260	CM	048.2	3" 76mm 60-90 CM
5.	120	CM	072.2	4.1/2" 114mm 30-60 CM
6.	60	CM	088.2	5.1/2" 140mm 30 CM
				BRASS GASKET GASKET SHIMS BRASS.
7.	40	Nos	200401/001.2	Brass shims 0.001"X6" wide (5 Ft Roll)
8.	40	Nos	002.2	Brass shims 0.0015" X6 " wide (5 Ft Roll)
				Free cutting brass round bar rod conforming to Astm B-16 : temper designation (HO2) round cross section :hot rolled :certificates is required : colour identification black Inches mm in random lengths
9.	120	CM	200505/112.2	7" 178 30-60 CM
				Cast iron bars to B.S.1452-1948 grade 12 rough machined to 1/32"above stated sizes in random lengths of 45-90CM round solid bars diameter (inches) dia Inches mm
10.	90	CM	206005/192.2	12" 305

IT.	QTY	UNIT	VOCAB NO.	DESCRIPTIN
				<p>Chemical composition 3.5- 5.8 % tin 0.03-0.35% phosphorous 0.10% max iron lead 0.05% max zinc 0.3% max copper plus tin plus phosphorous 99.5% min Phosphor bronze cold drawn and annealed in accordance with Astm designated B-139-52, alloy "A" colour identification: green. phosphor bronzes rods Dia inches mm in rand lengths</p>
11.	600	CM	202105/056.2	3.1/2" 89 120-300 CM
12.	120	CM	/080.2	5" 127 30-60 CM
				<p>Chemical composition :0.35-0.58% Tin 0.03-0.35% phosphorous ,0.10% max iron ,lead 0.05 % max zinc 0.3% max copper plus tin plus phosphorous 99.5% min phosphor bronze cold drawn and annealed in accordance with Astm designation hollow bronze bar Dia inches mm in random lengths O.DxI.D O.DxI.D</p>
13.	600	CM	202110/048.2	4"X2" 102X51 (1-1.5M)CM (30-60CM)
14.	400	CM	/072.2	6"X3" 152 X76 (30-60CM)
				<p>High lead tin bronze hollow bar casting according to ASTM B-144-52 alloy type (3B): commercial designation (83-7-7-3) color identification white dia inches mm in random length Inch mm</p>
15.	600	CM	202510/021.2	2"X3/4" 51X19 60-120CM
16.	600	CM	/028.2	2.1/2"X1" 64X25 120-240CM
				<p>Stainless steel bar according to Astm – A- 276-81 A type (304) UNS No. (S30400) cold finished :cold drawn: annealed</p>
17.	600	CM	203210/048.2	76X38 mm 30-60CM

IT.	QTY	UNIT	VOCAB NO.	DESCRIPTIN
				Martensitic round bar martensitic stainless steel round bar according to Astm -A-276-81A type (414) UNS designation (S41400):cold finished :cold drawn :annealed :Colour identification :red.
18.	720	CM	203405/036.2	2.1/4" 57mm 300-450CM
19.	100	CM	/110.2	175 mm 50 CM length
				Martensitic hollow round bar Stainless steel round bar according to : ASTM A-276 type (414) UNS designation (S4 1400) Cold finished ,cold drawn, annealed Color identification : red OD X ID
20.	600	CM	203410/080.2	5 x 3" or 127x76mm
				Standard quality :cold finished low carbon steel bar :cold drawn in accordance with Astm -A-108-81 grade designation (1018): UNS No designation (G10180) colour identification black inches mm in random lengths
21.	600	CM	205105/040.2	2.1/2" 64 300-450CM
				Standard quality :cold finished cold drawn: medium-carbon steel square bar : in accordance with Astm -A-108-81 grade designation (1144): UNS No (G11440) Inches mm in random lengths
22.	600	CM	205315/006.2	3/8X3/8" 10X10 300-450CM

ALL COUNTRIES ACCEPTED EXCEPT CHAINA

- CERTIFICATE OF ORIGIN REQUIRED
- MILL CERTIFICATE
- DIMENSIONS CHECK
- THIRD PART INSPECTION(chemical composition test & ultrasonic test)
 - 1- Lloyds Register
 - 2- Bureau Veritas
 - 3- Intertek Global
 - 4- Tuv Rhenland
 - 5- DNV

DELIVERY PERIOD (120 DAYS)

MINISTRY OF OIL
MIDLAND REFINERIES CO. (G.CO.)
(DAURA REFINERY)

ADVERTISEMENT
MIDLAND REFINERIES CO. ANNOUNCES FOR PURCHASING THE MATERIALS AS STATED BELOW:-

REQ.NO.	DESCRIPTION	QTY	ADVERTISEMENT NO.	BID BOND
1220/2017	METALS	22 ITEMS	TWICE	1800 \$

1-The requisition to be sold in (250, 000) Iraqi dinars; un returnable or to transfer this amount to MRC Bank account number (90956)in Rafidan Bank head branch .

2-Technical and commercial offer should be opened at the same time, the representatives of the companies can be attend to our company (MRC) at 10 o'clock morning one day after the closing day stated below in item (28) .

3-Offered prices should be (CIP) Baghdad / Daura Refinery and preferred to be in us dollar. they will be final and nonnegotiable . (MRC) is not obliged to accept the lowest prices.

4-offeres (TECHNICAL & COMMERCIAL) to be submitted, separately in sealed envelopes, either directly at (MRC) reception bureau or sent by (DHL). the requisition number, the description and the closing date should be fixed on both envelopes. the validity of the offer should be mentioned within the technical offer ; also on the envelope of the commercial offer. offers sent by e- mail will be neglected.

5- The validity of the bid bond and the offer should be mentioned within both offers and should not be less than (120) days.

6- All pages of, both, the technical and commercial offers should be numbered in sequence, including the attachments and documents.

7-All documents (profile) (new establishment certificate stamped from the Iraqi embassy in your country financial statement accounts for the last two year (balance sheet) exemption letter issued from general commission for tax contain the taxes number and similar contracts achieved, issued by concerned contracting sides enclosed with the technical offer before purchasing the requisition.

8- A BID BOND OF AMOUNT THAT STATED IN THE ADVERTISEMENT ABOVE AGAINST EACH TENDER SHOULD BE SUBMITTED WITH COMMERCIAL OFFER FROM ONE OF THE PARTICIPANT IN THE COMPANY ACCORDING TO INSTRUCTION AS(LETTER OF GUARANTEE , CERTIFIED CHEQUE OR BILL OF EXCHANGE) (ORIGINAL COPY), ISSUED FROM :((HUDA BANK , ALBILAD ISLAMIC BANK FOR INVESTMENT AND FINANCE , TRADE BANK OF IRAQ , KURDISTAN INTERNATIONAL BANK FOR INVESTMENT AND DEVELOPMENT , ERBIL BANK , CIHAN BANK FOR ISLAMIC INVESTMENT AND FINANCE , NATIONAL ISLAMIC BANK , MANSOUR BANK FOR INVESTMENT , REGION FOR BUSINESS INVESTMENT AND FINANCING (EMERALD BANK BEFORE), BANK OF BAGHDAD , GULF COMMERCIAL BANK, SUMER COMMERCIAL BANK , CREDIT BANK OF IRAQ , NATIONAL BANK OF IRAQ , INVESTMENT BANK OF IRAQ , ASHUR INTERNATIONAL BANK FOR INVESTMENT , IRAQI ISLAMIC BANK FOR INVESTMENT AND DEVELOPMENT , INTERNATIONAL DEVELOPMENT BANK INVESTMENT AND FINANCE , COMMERCIAL BANK OF IRAQ , BYBLOS BANK , IRAQ IMDLEST BANK OF INVESTMENT , BANK MED , ISLAMIC REGIONAL COOPERATION BANK FOR DEVELOPMENT AND INVESTMENT)) AND RELEASED IMMEDIATELY IN CASE THE REQUISITION IS NOT AWARDED. OFFERS WITHOUT BID BOND WILL BE NEGLECTED . BID BOND ISSUED FROM ((ASIA BANK , DAR ESSALAAM INVESTMENT BANK , NORTH BANK FOR FINANCIAL AND INVESTMENT , DIJLAH AND FURAT BANK , WARKA BANK FOR INVESTMENT & FINANCE , THE BANK OF BASRAH INTERNATIONAL , UNITED BANK FOR INVESTMENT , ECONOMY FOR INVESTMENT AND FINANCE , UNION BANK OF IRAQ , ALRAWAHEL ISLAMIC INVESTMENT AND FINANCE BANK)) ARE NOT ACCEPTABLE . THIS BID BOND SHOULD BE VALID FOR NOT LESS THAN (120) DAYS (OFFERS WHICH CONTAIN BID BOND AS A SWIFT WILL BE NEGLECTED).

9- the delivery period (in days) should be, exactly specified.

10- Basic terms of payment is by irrevocable & unconfirmed letter of credit to be paid (100%) after the receipt of goods in baghdad complete and as ordered. other terms of payment may be, mutually, agreed upon later and for certain conditions, which are : a portion of the total amount to be paid, but against bank guarantee the prices of all offers are calculated according to the exchange rate of the central bank of iraq .at the date of opening the offers .for the purpose of preferability and by iraqi dinar only , for iraqi companies according to the exchange rate of the central bank of iraq at the date of preparing the contract,and the cost was stated in the contract.

11- Delay penalty to be applied with total amount, not exceeding (10%) of the total value of the contract .

12- An unconditional performance bond of (5%) of the total value of the contract to be submitted, from one of the participant in the company as a letter of guarantee (only) after the letter of award and before signing the contract according to instruction , from one of the banks mentioned in item (8) within (15) fifteen days from the date, the supplier is informed of the award. for any delay beyond the specified period, the award will be cancelled and the supplier will be considered as a shirker. the performance bond should be valid throughout the period of the contract or extending it upon extending the period of supply or until the guarantee period (if stated), is over. this performance bond will be released after the receipt of goods complete and as ordered and the supplier has fulfilled all his commitments regarding the contract otherwise, it will be confiscated by our company

- 13- (2.7%) of the total value of the contract to be deducted as taxes for iraqi companies. also, in case the payment is in iraqi dinar. for non-iraqi companies, the deducted amounts shall be transferred to the general commission of taxes within a period not exceeding (30) days from the date of completing the work and 3% for the contract contain onsite training , installation and operation not to pay the final payment to the second party and not to settle the final account unless after a written approval issued by the general commission for taxes, or deducting a percentage of 10% from it and sent it to the general commission for taxes before the release the final payment , whether the contract execution is in one payment or in multiple payments .
- 14- (0.003) off the total value of the contract to be deducted as stamp charges.
- 15- A sum of (205,000.00) id to be deducted as cost of import license.
- 16- Origin certificate should be approved by iraqi embassy/commercial attaché in the country of origin.
- 17- a sum of money in iraqi dinar for chemical materials to be deducted as an environmental cost after issuing the contract & will be determined by ministry of environment (for chemical materials only).
- 18- The participant has no right to omit or make any amendment, whatsoever, to any of the paragraphs of the requisition document.
- 19- The origin of the materials should be specified in the offer and fixed. and will not be changed for any reason and should be from the requested origin . State the method & the port of shipment & the entry point .
- 20- The supplier should state his full and fixed name and address
(Country , City , Street, Building, Email ,Phone NO.)
ALL offers and correspondences should be, clearly, signed by the general manager or whom is officially empowered via power of attorney. otherwise the offer will be neglected.
- 21- Third party inspection certificate should be provided from one of the following companies:
[LLOYDS REGISTER – BUREAU VERITAS - INTERTEK GLOBAL - TUV RHEINLAND - DNV]
- 22- It is necessary to present authorization letter from the manufacturer companies certified from ministry of foreign affairs or embassy or consulate or the commercial attached in country of origin (original copy)
(for tenders of specific materials)
- 23- The awarded supplier will bear the advertising fees value (150 \$) .
- 24- Iraqi laws are applied : the tender and the contract shall be governed and construed according to the iraqi law. courts shall have the exclusive jurisdiction to hear and determine all actions and proceedings arising out of the contract. governmental debts collection law (no. : 56), for the year 1977 shall be applied on amounts owed to (MRC).
- 25- For chemical (Req) the sample should be submitted with the technical & commercial offers before or (during)the closing otherwise the offers will be neglected
- 26- The contracted company shall not deal with Israel in any way ; otherwise , it shall bear all the legal consequences .
- 27-The companies that need any additional information in order to participate in any tender should buy the tender document & attached with their letters before closing date & our company shall state a date of conference for answering all questions in time not less than (7 day) before closing date
- 28- Closing date: 28 / 8 / 2017, till (1.00) o'clock (afternoon).**
- 29- All the procedure of the requirements governed by implementing Instructions of government contract No.2 for the Year 2014 , regulations and its amendments
- Note:** you can find the conditions of submitting offers on website: www.oil.gov.iq - www.mrc.oil.gov.iq

G. MANAGER

info@mrc.oil.gov.iq
purchase@mrc.oil.gov.iq

البريد الالكتروني لشركة مصافي الوسط

REQ.NO. – 1220 /2017

IT.	QTY	UNIT	VOCAB NO.	DESCRIPTIN
				METALS
				Aluminum alloy bar Astm B-211 alloy (1060): min .AL %99.6. round bar cross section :cold finished , yield strength tests are required length 25 CM
1.	280	CM	200105/048.2	3"X25 CM
2.	310	CM	200105/064.2	4" X25 CM
				Aluminum bronze rod conforming to Astm B-150 -82: copper alloy UNS No.(C63200): strength classification (HR 50) hot rolled and annealed Certificate is required. Colour identification: silver Inches mm in random lengths
3.	180	CM	200205/044.2	2.3/4" 70mm 60-90 CM
4.	260	CM	048.2	3" 76mm 60-90 CM
5.	120	CM	072.2	4.1/2" 114mm 30-60 CM
6.	60	CM	088.2	5.1/2" 140mm 30 CM
				BRASS GASKET GASKET SHIMS BRASS.
7.	40	Nos	200401/001.2	Brass shims 0.001"X6" wide (5 Ft Roll)
8.	40	Nos	002.2	Brass shims 0.0015" X6 " wide (5 Ft Roll)
				Free cutting brass round bar rod conforming to Astm B-16 : temper designation (HO2) round cross section :hot rolled :certificates is required : colour identification black Inches mm in random lengths
9.	120	CM	200505/112.2	7" 178 30-60 CM
				Cast iron bars to B.S.1452-1948 grade 12 rough machined to 1/32"above stated sizes in random lengths of 45-90CM round solid bars diameter (inches) dia Inches mm
10.	90	CM	206005/192.2	12" 305

IT.	QTY	UNIT	VOCAB NO.	DESCRIPTIN
				<p>Chemical composition 3.5- 5.8 % tin 0.03-0.35% phosphorous 0.10% max iron lead 0.05% max zinc 0.3% max copper plus tin plus phosphorous 99.5% min Phosphor bronze cold drawn and annealed in accordance with Astm designated B-139-52, alloy "A" colour identification: green. phosphor bronzes rods Dia inches mm in rand lengths</p>
11.	600	CM	202105/056.2	3.1/2" 89 120-300 CM
12.	120	CM	/080.2	5" 127 30-60 CM
				<p>Chemical composition :0.35-0.58% Tin 0.03-0.35% phosphorous ,0.10% max iron ,lead 0.05 % max zinc 0.3% max copper plus tin plus phosphorous 99.5% min phosphor bronze cold drawn and annealed in accordance with Astm designation hollow bronze bar Dia inches mm in random lengths O.Dxl.D O.Dxl.D</p>
13.	600	CM	202110/048.2	4"X2" 102X51 (1-1.5M)CM (30-60CM)
14.	400	CM	/072.2	6"X3" 152 X76 (30-60CM)
				<p>High lead tin bronze hollow bar casting according to ASTM B-144-52 alloy type (3B): commercial designation (83-7-7-3) color identification white dia inches mm in random length Inch mm</p>
15.	600	CM	202510/021.2	2"X3/4" 51X19 60-120CM
16.	600	CM	/028.2	2.1/2"X1" 64X25 120-240CM
				<p>Stainless steel bar according to Astm – A- 276-81 A type (304) UNS No. (S30400) cold finished :cold drawn: annealed</p>
17.	600	CM	203210/048.2	76X38 mm 30-60CM

IT.	QTY	UNIT	VOCAB NO.	DESCRIPTIN
				Martensitic round bar martensitic stainless steel round bar according to Astm -A-276-81A type (414) UNS designation (S41400):cold finished :cold drawn :annealed :Colour identification :red.
18.	720	CM	203405/036.2	2.1/4" 57mm 300-450CM
19.	100	CM	/110.2	175 mm 50 CM length
				Martensitic hollow round bar Stainless steel round bar according to : ASTM A-276 type (414) UNS designation (S4 1400) Cold finished ,cold drawn, annealed Color identification : red OD X ID
20.	600	CM	203410/080.2	5 x 3" or 127x76mm
				Standard quality :cold finished low carbon steel bar :cold drawn in accordance with Astm -A-108-81 grade designation (1018): UNS No designation (G10180) colour identification black inches mm in random lengths
21.	600	CM	205105/040.2	2.1/2" 64 300-450CM
				Standard quality :cold finished cold drawn: medium-carbon steel square bar : in accordance with Astm -A-108-81 grade designation (1144): UNS No (G11440) Inches mm in random lengths
22.	600	CM	205315/006.2	3/8X3/8" 10X10 300-450CM

ALL COUNTRIES ACCEPTED EXCEPT CHAINA

- CERTIFICATE OF ORIGIN REQUIRED
- MILL CERTIFICATE
- DIMENSIONS CHECK
- THIRD PART INSPECTION(chemical composition test & ultrasonic test)
 - 1- Lloyds Register
 - 2- Bureau Veritas
 - 3- Intertek Global
 - 4- Tuv Rhenland
 - 5- DNV

DELIVERY PERIOD (120 DAYS)

أعلان رقم (ب- ٢٨) لسنة ٢٠١٧

تعلن شركة مصافي الوسط عن اعلان الطلبات الاستيرادية كما مبين أدناه :-

REQ.NO.	DESCRIPTION	QTY	ADVERTISEMENT NO.	BID BOND
1247/2017	JOINTING & PACKING	12 ITEMS	TWICE	750 \$

وبالشروط التالية :-

- ١- يتم بيع مواصفات الطلبية بمبلغ ٢٥٠٠٠٠ (مئتان وخمسون الف) دينار عراقي غير قابل للرد او تحويل ذلك المبلغ الى المصرف الخاص لشركتنا (مصرف الرافدين) الفرع الرئيسي ورقم الحساب هو ٩٠٩٥٦
- ٢- يتم فتح العروض الفنية والتجارية في ان واحد (في اليوم الذي يلي تاريخ الغلق) وفي حالة مصادفة عطلة توّجّل الى اليوم التالي وبالامكان حضور ممثلي الشركات الى مقر شركتنا عند الساعة العاشرة من اليوم الذي يلي تاريخ الغلق و المثبت في الفقرة (٢٨) ادناه
- ٣- يفضل تقديم الاسعار بعملة الدولار (CIP) واصل بغداد / شركة مصافي الوسط وتكون الاسعار نهائية وغير قابلة للتفاوض وشركتنا غير ملزمة بقبول أو طأ الاسعار.
- ٤- يتم تقديم عرضين مغلقين (فني وتجاري) منفصلين مثبت عليهما رقم المناقصة وعنوانها وتاريخ الغلق وموقعين من قبل المدير العام أو المدير المفوض مع تثبيت الاسم الكامل وعليهما ختم الشركات في الصندوق الخاص في استعلامات شركتنا تقبل العروض التي ترسل مغلفة بالبريد أو D.H.L وتهمل العروض التي ترد بعد تاريخ الغلق أو عن طريق البريد الالكتروني.
- ٥- يجب تحديد فترة نفاذية العرض ضمن العرض الفني وكذلك توثيقها على الظرف الخاص بالعرض التجاري وكذلك تحديد تاريخ نفاذية التامينات الأولية في كلا العرضين ويجب ان لا تقل مدة نفاذ العروض عن (١٢٠ يوما).
- ٦- ترقيم كل صفحة من صفحات الطء (الفني والتجاري) مع المرفقات.
- ٧- على الشركات الراغبة في المشاركة تقديم كافة المستمسكات الاصولية والقانونية الخاصة بالشركة (شهادة تاسيسية حديثة ونافاذة ومصدقة حسب الاصول من السفارة أو القنصلية العراقية في بلد الشركة – براءة ذمة صادرة من الهيئة العامة للضرائب تتضمن الرقم الضريبي – الموقف المالي متمثل بحسابات ختامية لآخر سنتين مالية – الهوية التجارية النافذة) مع تقديم الاعمال المماثلة صادرة من قبل جهات التعاقد المعنية قبل شراء الطلبية أو ترفق مع العرض الفني المقدم في حالة عدم تقديمها سابقاً
- ٨- يتم تقديم تامينات أولية ودسب المبالغ المثبتة امام كل طلبية في الاعلان اعلاه من قبل احد المساهمين في الشركة ودسب التعليمات وترفق مع العرض التجاري (خطاب ضمان او صك مصدق او سفتجة) نسخة اصلية صادرة من احد المصارف العراقية (مصرف الهدي ، البلاد الاسلامي للاستثمار والتمويل المصرف العراقي للتجارة ، مصرف كوردستان الدولي للاستثمار والتنمية ، مصرف اربيل ، مصرف جيهان للاستثمار والتمويل ، الوطني الاسلامي ، المنصور للاستثمار ، الاقليم التجاري للاستثمار والتمويل (اميرالد سابقا) ، مصرف بغداد ، مصرف الخليج التجاري ، سومر التجاري ، الائتمان العراقي ، الاهلي العراقي ، الاستثمار العراقي ، اشور الدولي للاستثمار ، العراقي الاسلامي للاستثمار والتنمية ، التتمية الدولي للاستثمار والتمويل ، التجاري العراقي ، مصرف بيبيلوس اللباني ، مصرف الشرق الاوسط العراقي للاستثمار ، البحر المتوسط ، مصرف التعاون الاسلامي للاستثمار) وكافة فروع المصارف الاجنبية العاملة في العراق وترفق مع العرض التجاري وتطلق هذه التامينات في حالة عدم احوالة الطلبية عليكم وتهمل العروض التي لم ترفق بها التامينات الأولية. ترفض التامينات الأولية الصادرة من (بنك اسيا التركي ، دار السلام للاستثمار ، مصرف الشمال ، مصرف دجلة والفرات للتنمية والاستثمار و مصرف الوركاء للاستثمار والتمويل ومصرف البصرة الدولي و المصرف المتحد للاستثمار ومصرف الاقتصاد للاستثمار و التمويل ومصرف الاتحاد العراقي ، مصرف الرواحل الاسلامي للاستثمار والتمويل) ويجب ان تكون هذه التامينات نافذة لمدة لا تقل عن (١٢٠) يوما (تهمل العروض اذا كانت التامينات الأولية على شكل سويفت) .
- ٩- تحديد فترة التجهيز بالايام ولا يجوز تثبيت عبارة (من – الى) .
- ١٠- شروط الدفع/ اعتماد مستندي غير مثبت وغير قابل للنقض أو التحويل تطلق المستحقات (١٠٠ %) بعد استلام المواد كاملة ومطابقة للمواصفات في مصفى الدورة و يمكن الاتفاق على نسب أخرى مقابل كفالته مصرفيه ضامنه يتم احتساب اسعار جميع العطاءات لاغراض المفاضله على اسس موحد و بموجب نشرة البنك المركز العراقي يوم الفتح ويكون الدفع بالدينار العراقي فقط للشركات العراقية ويتم احتساب الاسعار على اساس نشرة البنك المركزي العراقي ليوم اعداد العقد ويثبت المبلغ في العقد
- ١١- ترفض غرامة تاخيرية على المجهز لا يتجاوز حدها الأعلى نسبة ١٠ % من مبلغ عقد في حالة عدم تجهيز المواد بفترة التجهيز المثبتة في العقد.
- ١٢- تقدم التامينات النهائية على شكل خطاب ضمان حسن تنفيذ (حصرا) للعقد بنسبة (٥%) خمسة من المئة من مبلغ العقد بعد التبليغ بكتاب الاحالة وقيل توقيع العقد ومن احد المصارف الواردة في الفقرة رقم ٨ خلال مدة لا تتجاوز (١٥) يوما" وكشرط لتفعيل الاعتماد وفي حالة التأخر، تهمل الاحالة ويحال المجهز إلى لجنة الناقلين. وتبقى الكفالة نافذة لمدة العقد او تمديده عند تمديد فترة التجهيز او لحين انتهاء فتره الضمان، في حاله وجود (فترة ضمان) تطلق كفالة حسن الاداء بعد استلام المواد كاملة ومطابقة للمواصفات وبعد انجاز المجهز كافة التزامات المنصوصه في العقد وبخلافه سيتم مصادرتها من قبل شركتنا .
- ١٣- سيتم استقطاع نسبة (٢,٧ %) من قيمة العقد كضريبة وذلك بالنسبة للشركات العراقية وايضا في حالة الدفع بالدينار العراقي اما في حالة الشركات الغير عراقية فيتم حجز هذه النسبة كإمانات ضريبية وتطلق بعد ان يقوم المجهز بترويدنا ببراءة ذمة من الهيئة العامة للضرائب وبخلافه سيتم إحالة هذه الامانات إلى الهيئة العامة للضرائب خلال مدة لا تزيد عن (٣٠) يوم من تاريخ انجاز العمل وتكون النسبة ٣ % للعقود المتضمنة نصب واشراف موقعي ولا يتم صرف الدفعة الاخيرة للمقاولين والمتعاقدين وعدم تسوية الحساب النهائي للمقاول الاموافقة تحريرية من الهيئة العامة للضرائب او استقطاع مانسبته (١٠%) عشرة من المئة منها وارسالها الى الهيئة العامة للضرائب قبل اطلاق الدفعة الاخيرة سواء اكان تنفيذ العقد على دفعة واحدة ام على عدة دفعات .
- ١٤- تستقطع نسبة (٠,٠٠٣) من مبلغ العقد كرسوم طابع .
- ١٥- يستقطع مبلغ (٢٥٥٠٠٠) دينار عراقي من مبلغ العقد عن قيمة اجازة الاستيراد.
- ١٦- شهادة المنشأ يجب ان تكون مصدقة من قبل الملحقية التجارية العراقية أو السفارة في بلد المنشأ .
- ١٧- سيتم استقطاع مبلغ الاجور البيئية بعد اصدار العقد بموجب ما يتم تحديده من قبل وزارة البيئة (للمواد الكيماوية حصرا)
- ١٨- لا يجوز لمقدم الطء شطب أي بند من بنود مستندات المناقصة أو إجراء أي تعديل فيها مهما كان نوعه .
- ١٩- منشأ المواد ينبغي ان يحدد في العرض ويكون من ضمن المنشأ المطلوبة وثابت (لن يتغير لأي سبب كان) مع تحديد طريقة وميناء الشحن منفذ الدخول .
- ٢٠- يقوم المجهز بتثبيت عنوانه الكامل (الدولة – المدينة – الشارع – البناية – العنوان البريدي والهاتف) و اسم المدير العام للشركة أو من يخولهم في العروض والمراسلات وبشكل واضح ورسمي وبخلافه يهمل العرض .

٢١- تقديم شهادة فحص طرف ثالث من إحدى الشركات التالية :

[LLOYD'S REGISTER – BUREAU VERITAS - INTERTEK GLOBAL - TUV RHEINLAND - DNV]

- ٢٢- تقديم كتاب تخويل من الشركات المصنعة مصدقة من وزارة الخارجية او السفارة او القنصلية او الملحقية التجارية في بلد المنشأ (نسخة اصليّة) وحسب التعليمات لطليبات (تجهيز المواد المتخصصة) .
- ٢٣- يتحمل من ترسو عليه المناقصة أجور نشر الإعلان مقدارها (١٥٠ دولار)
- ٢٤-تطبيق القوانين والتعليمات المعمول بها في العراق في حالة وقوع منازعات أو في كل ما لم يرد به نص ويكون النزاع خاضعاً لولاية القضاء العراقي مع تطبيق قانون تحصيل الديون الحكومية رقم ٥٦ لسنة ١٩٧٧ بأن المستحقات المالية تترتب لشركتنا بذمة الطرف الآخر .
- ٢٥- في طلبيات المواد الكيماوية يجب ان تقدم النماذج خلال فترة الغلق (مع العروض الفنية والتجارية) وبخلافه سيتم اهمال العروض .
- ٢٦-عدم تعامل الشركة المتعاقد معها مع اسرائيل باي شكل من الاشكال ، وبخلافه تتحمل كافة التبعات القانونية .
- ٢٧-يتوجب على الشركات التي ترغب بالمشاركة في اي طلبية والتي تطلب اي معلومات فنية شراء الطلبية ويتم ارفاق وصل الشراء مع الرسالة وقيل مدة مناسبة من تاريخ الغلق وستقوم شركتنا بتحديد تاريخ انعقاد المؤتمر الخاص بالاجابة عن استفسارات المشتركين في المناقصة وقيل موعد لايقبل عن (٧) ايام من تاريخ غلق المناقصة .
- ٢٨-تاريخ الغلق الساعة (١) بعد الظهر ليوم ٢٨ / ٨ / ٢٠١٧ .
- ٢٩- كافة الاجراءات لطليبات الشراء خاضعة لتعليمات تنفيذ العقود الحكومية رقم (٢) لسنة ٢٠١٤ والضوابط والتعديلات .

ملاحظة يمكن الاطلاع على شروط تقديم العطاءات وعلى الموقع الالكتروني :- www.oil.gov.iq
www.mrc.oil.gov.iq

----- مع التقدير

زيد كاظم شريف
المدير العام/ وكالة

IT	QTY	UNIT	VOCAB	DESCRIPTION
				JOINTING & PACKING
				Teflon sheets john crane style 68c
1.	4	Sht	191131/002.2	PTFE sheet 1/32" X36"X36"
2.	4	Sht	004.2	PTFE sheet 1/8"X40"X40"
				Oil and petrol resisting rubber sheet jointing having excellent resistance to lubricating and fuel oils petroleum distills and hydraulic fluids also having smooth surface and uniform thickness.
3.	300	Ft	191240/101.2	rubber inserion 1/8" thick X36" wide
4.	10	Ft	110.2	Felt 60" wide X 1/4" thick
				Sheet gasket style bs2815-1973 grade A manufactured from high quality of chrysofile asbestos fiber and raw materials * applications: to use with Saturated steam, oxygen Distillates ,oil and fats , Alcohols, solvent ,dyes * max. temperature 550 C ⁰ * Max. Pressure 150 KG/CM ²
5.	30	Sht	191301/020.2	40" X 40" X 1/32" Thickness
6.	101	Sht	033.2	60" X 60" X 1/16" Thickness
7.	130	Sht	191301/041.2	80" X 60" X 1/32" Thickness
8.	8	Sht	044.2	80" X 60" X 1/8" Thickness
9.	6	Sht	046.2	80" X 80" X 1/8" Thickness
				Sheet gasket STYLE IS-2712-1979 Grade A/1 THIS IS Specialized Asbestos Fiber jointing Sheet Which Is Intimately Bonded With An Acid Resisting Compound To Withstand The Corrosive Action Of Acids And Chemicals * Application: Concentrated Organic, Acids, And Chemical Industries, * Max. Temperature 210 C ⁰ * Max. Pressure 150 KG/CM ²
10.	50	Sht	191303/023.2	40" X 40" X 1/8" Thickness
11.	10	Sht	044.2	80" X 60" X 1/8" Thickness

IT	QTY	UNIT	VOCAB	DESCRIPTION
				Sheet gasket STYLE BS-1832-1972 a Compressed Fiber, jointing bonded with a sophisticated compound * applications: for oil and petrochemical plants , solvents , oils, pipelines , petrochemical fields , distillates oil, and petroleum, hydrocarbons refrigerants. * Max. Temperature 550 C⁰ * Max. Pressure 150 KG/CM²
12.	55	Sht	191304/032.2	60" X 60" X 1/32" Thickness

ALL COUNTRIES ACCEPTED EXCEPT CHAINA

- **CERTIFICATE OF ORIGIN**
- **MILL CERTIFICATE**
- **DIMENSIONS CHECK**

- **THIRD PART INSPECTION(chemical composition test)**
 - 1- Lloyds Register
 - 2- Bureau Veritas
 - 3- Intertek Global
 - 4- Tuv Rhenland
 - 5- DNV

DELIVERY PERIOD (120 DAYS)

MINISTRY OF OIL
MIDLAND REFINERIES CO. (G.CO.)
(DAURA REFINERY)

ADVERTISEMENT
MIDLAND REFINERIES CO. ANNOUNCES FOR PURCHASING THE MATERIALS AS STATED BELOW:-

REQ.NO.	DESCRIPTION	QTY	ADVERTISEMENT NO.	BID BOND
1247/2017	JOINTING & PACKING	12 ITEMS	TWICE	750 \$

1-The requisition to be sold in (250, 000) Iraqi dinars; un returnable or to transfer this amount to MRC Bank account number (90956)in Rafidan Bank head branch .

2-Technical and commercial offer should be opened at the same time, the representatives of the companies can be attend to our company (MRC) at 10 o'clock morning one day after the closing day stated below in item (28) .

3-Offered prices should be (CIP) Baghdad / Daura Refinery and preferred to be in us dollar. they will be final and nonnegotiable . (MRC) is not obliged to accept the lowest prices.

4-offeres (TECHNICAL & COMMERCIAL) to be submitted, separately in sealed envelopes, either directly at (MRC) reception bureau or sent by (DHL). the requisition number, the description and the closing date should be fixed on both envelopes. the validity of the offer should be mentioned within the technical offer ; also on the envelope of the commercial offer. offers sent by e- mail will be neglected.

5- The validity of the bid bond and the offer should be mentioned within both offers and should not be less than (120) days.

6- All pages of, both, the technical and commercial offers should be numbered in sequence, including the attachments and documents.

7-All documents (profile) (new establishment certificate stamped from the Iraqi embassy in your country financial statement accounts for the last two year (balance sheet) exemption letter issued from general commission for tax contain the taxes number and similar contracts achieved, issued by concerned contracting sides enclosed with the technical offer before purchasing the requisition.

8- A BID BOND OF AMOUNT THAT STATED IN THE ADVERTISEMENT ABOVE AGAINST EACH TENDER SHOULD BE SUBMITTED WITH COMMERCIAL OFFER FROM ONE OF THE PARTICIPANT IN THE COMPANY ACCORDING TO INSTRUCTION AS(LETTER OF GUARANTEE , CERTIFIED CHEQUE OR BILL OF EXCHANGE) (ORIGINAL COPY), ISSUED FROM :((HUDA BANK , ALBILAD ISLAMIC BANK FOR INVESTMENT AND FINANCE , TRADE BANK OF IRAQ , KURDISTAN INTERNATIONAL BANK FOR INVESTMENT AND DEVELOPMENT , ERBIL BANK , CIHAN BANK FOR ISLAMIC INVESTMENT AND FINANCE , NATIONAL ISLAMIC BANK , MANSOUR BANK FOR INVESTMENT , REGION FOR BUSINESS INVESTMENT AND FINANCING (EMERALD BANK BEFORE), BANK OF BAGHDAD , GULF COMMERCIAL BANK, SUMER COMMERCIAL BANK , CREDIT BANK OF IRAQ , NATIONAL BANK OF IRAQ , INVESTMENT BANK OF IRAQ , ASHUR INTERNATIONAL BANK FOR INVESTMENT , IRAQI ISLAMIC BANK FOR INVESTMENT AND DEVELOPMENT , INTERNATIONAL DEVELOPMENT BANK INVESTMENT AND FINANCE , COMMERCIAL BANK OF IRAQ , BYBLOS BANK , IRAQ IMDLEST BANK OF INVESTMENT , BANK MED , ISLAMIC REGIONAL COOPERATION BANK FOR DEVELOPMENT AND INVESTMENT)) AND RELEASED IMMEDIATELY IN CASE THE REQUISITION IS NOT AWARDED. OFFERS WITHOUT BID BOND WILL BE NEGLECTED . BID BOND ISSUED FROM ((ASIA BANK , DAR ESSALAAM INVESTMENT BANK , NORTH BANK FOR FINANCIAL AND INVESTMENT , DIJLAH AND FURAT BANK , WARKA BANK FOR INVESTMENT & FINANCE , THE BANK OF BASRAH INTERNATIONAL , UNITED BANK FOR INVESTMENT , ECONOMY FOR INVESTMENT AND FINANCE , UNION BANK OF IRAQ , ALRAWAHEL ISLAMIC INVESTMENT AND FINANCE BANK)) ARE NOT ACCEPTABLE . THIS BID BOND SHOULD BE VALID FOR NOT LESS THAN (120) DAYS (OFFERS WHICH CONTAIN BID BOND AS A SWIFT WILL BE NEGLECTED).

9- the delivery period (in days) should be, exactly specified.

10- Basic terms of payment is by irrevocable & unconfirmed letter of credit to be paid (100%) after the receipt of goods in baghdad complete and as ordered. other terms of payment may be, mutually, agreed upon later and for certain conditions, which are : a portion of the total amount to be paid, but against bank guarantee the prices of all offers are calculated according to the exchange rate of the central bank of iraq .at the date of opening the offers .for the purpose of preferability and by iraqi dinar only , for iraqi companies according to the exchange rate of the central bank of iraq at the date of preparing the contract,and the cost was stated in the contract.

11- Delay penalty to be applied with total amount, not exceeding (10%) of the total value of the contract .

12- An unconditional performance bond of (5%) of the total value of the contract to be submitted, from one of the participant in the company as a letter of guarantee (only) after the letter of award and before signing the contract according to instruction , from one of the banks mentioned in item (8) within (15) fifteen days from the date, the supplier is informed of the award. for any delay beyond the specified period, the award will be cancelled and the supplier will be considered as a shirker. the performance bond should be valid throughout the period of the contract or extending it upon extending the period of supply or until the guarantee period (if stated), is over. this performance bond will be released after the receipt of goods complete and as ordered and the supplier has fulfilled all his commitments regarding the contract otherwise, it will be confiscated by our company

- 13- (2.7%) of the total value of the contract to be deducted as taxes for iraqi companies. also, in case the payment is in iraqi dinar. for non-iraqi companies, the deducted amounts shall be transferred to the general commission of taxes within a period not exceeding (30) days from the date of completing the work and 3% for the contract contain onsite training , installation and operation not to pay the final payment to the second party and not to settle the final account unless after a written approval issued by the general commission for taxes, or deducting a percentage of 10% from it and sent it to the general commission for taxes before the release the final payment , whether the contract execution is in one payment or in multiple payments .
- 14- (0.003) off the total value of the contract to be deducted as stamp charges.
- 15- A sum of (205,000.00) id to be deducted as cost of import license.
- 16- Origin certificate should be approved by iraqi embassy/commercial attaché in the country of origin.
- 17- a sum of money in iraqi dinar for chemical materials to be deducted as an environmental cost after issuing the contract & will be determined by ministry of environment (for chemical materials only).
- 18- The participant has no right to omit or make any amendment, whatsoever, to any of the paragraphs of the requisition document.
- 19- The origin of the materials should be specified in the offer and fixed. and will not be changed for any reason and should be from the requested origin . State the method & the port of shipment & the entry point .
- 20- The supplier should state his full and fixed name and address
(Country , City , Street, Building, Email ,Phone NO.)
ALL offers and correspondences should be, clearly, signed by the general manager or whom is officially empowered via power of attorney. otherwise the offer will be neglected.
- 21- Third party inspection certificate should be provided from one of the following companies:
[LLOYDS REGISTER – BUREAU VERITAS - INTERTEK GLOBAL - TUV RHEINLAND - DNV]
- 22- It is necessary to present authorization letter from the manufacturer companies certified from ministry of foreign affairs or embassy or consulate or the commercial attached in country of origin (original copy)
(for tenders of specific materials)
- 23- The awarded supplier will bear the advertising fees value (150 \$) .
- 24- Iraqi laws are applied : the tender and the contract shall be governed and construed according to the iraqi law. courts shall have the exclusive jurisdiction to hear and determine all actions and proceedings arising out of the contract. governmental debts collection law (no. : 56), for the year 1977 shall be applied on amounts owed to (MRC).
- 25- For chemical (Req) the sample should be submitted with the technical & commercial offers before or (during)the closing otherwise the offers will be neglected
- 26- The contracted company shall not deal with Israel in any way ; otherwise , it shall bear all the legal consequences .
- 27-The companies that need any additional information in order to participate in any tender should buy the tender document & attached with their letters before closing date & our company shall state a date of conference for answering all questions in time not less than (7 day) before closing date
- 28- Closing date: 28 / 8 / 2017, till (1.00) o'clock (afternoon).**
- 29- All the procedure of the requirements governed by implementing Instructions of government contract No.2 for the Year 2014 , regulations and its amendments
Note: you can find the conditions of submitting offers on website: www.oil.gov.iq - www.mrc.oil.gov.iq

G. MANAGER

info@mrc.oil.gov.iq
purchase@mrc.oil.gov.iq

البريد الالكتروني لشركة مصافي الوسط

IT	QTY	UNIT	VOCAB	DESCRIPTION
				JOINTING & PACKING
				Teflon sheets john crane style 68c
1.	4	Sht	191131/002.2	PTFE sheet 1/32" X36"X36"
2.	4	Sht	004.2	PTFE sheet 1/8"X40"X40"
				Oil and petrol resisting rubber sheet jointing having excellent resistance to lubricating and fuel oils petroleum distills and hydraulic fluids also having smooth surface and uniform thickness.
3.	300	Ft	191240/101.2	rubber inserion 1/8" thick X36" wide
4.	10	Ft	110.2	Felt 60" wide X 1/4" thick
				Sheet gasket style bs2815-1973 grade A manufactured from high quality of chrysofile asbestos fiber and raw materials * applications: to use with Saturated steam, oxygen Distillates ,oil and fats , Alcohols, solvent ,dyes * max. temperature 550 C ⁰ * Max. Pressure 150 KG/CM ²
5.	30	Sht	191301/020.2	40" X 40" X 1/32" Thickness
6.	101	Sht	033.2	60" X 60" X 1/16" Thickness
7.	130	Sht	191301/041.2	80" X 60" X 1/32" Thickness
8.	8	Sht	044.2	80" X 60" X 1/8" Thickness
9.	6	Sht	046.2	80" X 80" X 1/8" Thickness
				Sheet gasket STYLE IS-2712-1979 Grade A/1 THIS IS Specialized Asbestos Fiber jointing Sheet Which Is Intimately Bonded With An Acid Resisting Compound To Withstand The Corrosive Action Of Acids And Chemicals * Application: Concentrated Organic, Acids, And Chemical Industries, * Max. Temperature 210 C ⁰ * Max. Pressure 150 KG/CM ²
10.	50	Sht	191303/023.2	40" X 40" X 1/8" Thickness
11.	10	Sht	044.2	80" X 60" X 1/8" Thickness

IT	QTY	UNIT	VOCAB	DESCRIPTION
				Sheet gasket STYLE BS-1832-1972 a Compressed Fiber, jointing bonded with a sophisticated compound * applications: for oil and petrochemical plants , solvents , oils, pipelines , petrochemical fields , distillates oil, and petroleum, hydrocarbons refrigerants. * Max. Temperature 550 C⁰ * Max. Pressure 150 KG/CM²
12.	55	Sht	191304/032.2	60" X 60" X 1/32" Thickness

ALL COUNTRIES ACCEPTED EXCEPT CHAINA

- **CERTIFICATE OF ORIGIN**
- **MILL CERTIFICATE**
- **DIMENSIONS CHECK**

- **THIRD PART INSPECTION(chemical composition test)**
 - 1- Lloyds Register
 - 2- Bureau Veritas
 - 3- Intertek Global
 - 4- Tuv Rhenland
 - 5- DNV

DELIVERY PERIOD (120 DAYS)

MINISTRY OF OIL
MIDLAND REFINERIES CO. (G.CO.)
(DAURA REFINERY)

ADVERTISEMENT
MIDLAND REFINERIES CO. ANNOUNCES FOR PURCHASING THE MATERIALS AS STATED BELOW:-

REQ.NO.	DESCRIPTION	QTY	ADVERTISEMENT NO.	BID BOND
1252/2017	FIRE & SAFETY EQUIPMENT	3 ITEMS	TWICE	960 \$

1-The requisition to be sold in (250, 000) Iraqi dinars; un returnable or to transfer this amount to MRC Bank account number (90956)in Rafidan Bank head branch .

2-Technical and commercial offer should be opened at the same time, the representatives of the companies can be attend to our company (MRC) at 10 o'clock morning one day after the closing day stated below in item (28) .

3-Offered prices should be (CIP) Baghdad / Daura Refinery and preferred to be in us dollar. they will be final and nonnegotiable . (MRC) is not obliged to accept the lowest prices.

4-offeres (TECHNICAL & COMMERCIAL) to be submitted, separately in sealed envelopes, either directly at (MRC) reception bureau or sent by (DHL). the requisition number, the description and the closing date should be fixed on both envelopes. the validity of the offer should be mentioned within the technical offer ; also on the envelope of the commercial offer. offers sent by e- mail will be neglected.

5- The validity of the bid bond and the offer should be mentioned within both offers and should not be less than (120) days.

6- All pages of, both, the technical and commercial offers should be numbered in sequence, including the attachments and documents.

7-All documents (profile) (new establishment certificate stamped from the Iraqi embassy in your country financial statement accounts for the last two year (balance sheet) exemption letter issued from general commission for tax contain the taxes number and similar contracts achieved, issued by concerned contracting sides enclosed with the technical offer before purchasing the requisition.

8- A BID BOND OF AMOUNT THAT STATED IN THE ADVERTISEMENT ABOVE AGAINST EACH TENDER SHOULD BE SUBMITTED WITH COMMERCIAL OFFER FROM ONE OF THE PARTICIPANT IN THE COMPANY ACCORDING TO INSTRUCTION AS(LETTER OF GUARANTEE , CERTIFIED CHEQUE OR BILL OF EXCHANGE) (ORIGINAL COPY), ISSUED FROM :((HUDA BANK , ALBILAD ISLAMIC BANK FOR INVESTMENT AND FINANCE , TRADE BANK OF IRAQ , KURDISTAN INTERNATIONAL BANK FOR INVESTMENT AND DEVELOPMENT , ERBIL BANK , CIHAN BANK FOR ISLAMIC INVESTMENT AND FINANCE , NATIONAL ISLAMIC BANK , MANSOUR BANK FOR INVESTMENT , REGION FOR BUSINESS INVESTMENT AND FINANCING (EMERALD BANK BEFORE), BANK OF BAGHDAD , GULF COMMERCIAL BANK, SUMER COMMERCIAL BANK , CREDIT BANK OF IRAQ , NATIONAL BANK OF IRAQ , INVESTMENT BANK OF IRAQ , ASHUR INTERNATIONAL BANK FOR INVESTMENT , IRAQI ISLAMIC BANK FOR INVESTMENT AND DEVELOPMENT , INTERNATIONAL DEVELOPMENT BANK INVESTMENT AND FINANCE , COMMERCIAL BANK OF IRAQ , BYBLOS BANK , IRAQ IMDLEST BANK OF INVESTMENT , BANK MED , ISLAMIC REGIONAL COOPERATION BANK FOR DEVELOPMENT AND INVESTMENT)) AND RELEASED IMMEDIATELY IN CASE THE REQUISITION IS NOT AWARDED. OFFERS WITHOUT BID BOND WILL BE NEGLECTED . BID BOND ISSUED FROM ((ASIA BANK , DAR ESSALAAM INVESTMENT BANK , NORTH BANK FOR FINANCIAL AND INVESTMENT , DIJLAH AND FURAT BANK , WARKA BANK FOR INVESTMENT & FINANCE , THE BANK OF BASRAH INTERNATIONAL , UNITED BANK FOR INVESTMENT , ECONOMY FOR INVESTMENT AND FINANCE , UNION BANK OF IRAQ , ALRAWAHEL ISLAMIC INVESTMENT AND FINANCE BANK)) ARE NOT ACCEPTABLE . THIS BID BOND SHOULD BE VALID FOR NOT LESS THAN (120) DAYS (OFFERS WHICH CONTAIN BID BOND AS A SWIFT WILL BE NEGLECTED).

9- the delivery period (in days) should be, exactly specified.

10- Basic terms of payment is by irrevocable & unconfirmed letter of credit to be paid (100%) after the receipt of goods in baghdad complete and as ordered. other terms of payment may be, mutually, agreed upon later and for certain conditions, which are : a portion of the total amount to be paid, but against bank guarantee the prices of all offers are calculated according to the exchange rate of the central bank of iraq .at the date of opening the offers .for the purpose of preferability and by iraqi dinar only , for iraqi companies according to the exchange rate of the central bank of iraq at the date of preparing the contract,and the cost was stated in the contract.

11- Delay penalty to be applied with total amount, not exceeding (10%) of the total value of the contract .

12- An unconditional performance bond of (5%) of the total value of the contract to be submitted, from one of the participant in the company as a letter of guarantee (only) after the letter of award and before signing the contract according to instruction , from one of the banks mentioned in item (8) within (15) fifteen days from the date, the supplier is informed of the award. for any delay beyond the specified period, the award will be cancelled and the supplier will be considered as a shirker. the performance bond should be valid throughout the period of the contract or extending it upon extending the period of supply or until the guarantee period (if stated), is over. this performance bond will be released after the receipt of goods complete and as ordered and the supplier has fulfilled all his commitments regarding the contract otherwise, it will be confiscated by our company

- 13- (2.7%) of the total value of the contract to be deducted as taxes for iraqi companies. also, in case the payment is in iraqi dinar. for non-iraqi companies, the deducted amounts shall be transferred to the general commission of taxes within a period not exceeding (30) days from the date of completing the work and 3% for the contract contain onsite training , installation and operation not to pay the final payment to the second party and not to settle the final account unless after a written approval issued by the general commission for taxes, or deducting a percentage of 10% from it and sent it to the general commission for taxes before the release the final payment , whether the contract execution is in one payment or in multiple payments .
- 14- (0.003) off the total value of the contract to be deducted as stamp charges.
- 15- A sum of (205,000.00) id to be deducted as cost of import license.
- 16- Origin certificate should be approved by iraqi embassy/commercial attaché in the country of origin.
- 17- a sum of money in iraqi dinar for chemical materials to be deducted as an environmental cost after issuing the contract & will be determined by ministry of environment (for chemical materials only).
- 18- The participant has no right to omit or make any amendment, whatsoever, to any of the paragraphs of the requisition document.
- 19- The origin of the materials should be specified in the offer and fixed. and will not be changed for any reason and should be from the requested origin . State the method & the port of shipment & the entry point .
- 20- The supplier should state his full and fixed name and address
(Country , City , Street, Building, Email ,Phone NO.)
ALL offers and correspondences should be, clearly, signed by the general manager or whom is officially empowered via power of attorney. otherwise the offer will be neglected.
- 21- Third party inspection certificate should be provided from one of the following companies:
[LLOYDS REGISTER – BUREAU VERITAS - INTERTEK GLOBAL - TUV RHEINLAND - DNV]
- 22- It is necessary to present authorization letter from the manufacturer companies certified from ministry of foreign affairs or embassy or consulate or the commercial attached in country of origin (original copy)
(for tenders of specific materials)
- 23- The awarded supplier will bear the advertising fees value (150 \$) .
- 24- Iraqi laws are applied : the tender and the contract shall be governed and construed according to the iraqi law. courts shall have the exclusive jurisdiction to hear and determine all actions and proceedings arising out of the contract. governmental debts collection law (no. : 56), for the year 1977 shall be applied on amounts owed to (MRC).
- 25- For chemical (Req) the sample should be submitted with the technical & commercial offers before or (during)the closing otherwise the offers will be neglected
- 26- The contracted company shall not deal with Israel in any way ; otherwise , it shall bear all the legal consequences .
- 27-The companies that need any additional information in order to participate in any tender should buy the tender document & attached with their letters before closing date & our company shall state a date of conference for answering all questions in time not less than (7 day) before closing date
- 28- Closing date: 11 / 9 / 2017, till (1.00) o'clock (afternoon).**
- 29- All the procedure of the requirements governed by implementing Instructions of government contract No.2 for the Year 2014 , regulations and its amendments
Note: you can find the conditions of submitting offers on website: www.oil.gov.iq - www.mrc.oil.gov.iq

G. MANAGER

info@mrc.oil.gov.iq
purchase@mrc.oil.gov.iq

البريد الالكتروني لشركة مصافي الوسط

IT.	QTY	UNIT	VOCAB NO	DESCRIPTION
				FIRE & SAFTEY EQUIPMENT.
				EYE PROTECTIVE. GOGGLES.
1.	5000	Nos	161402/080.0	<p>Clear (white) safety goggle</p> <ul style="list-style-type: none"> -wide vision safety glass & integral side shield for increased protection -moulded nose piece for comfort -adjustable length ratcheting side arms ensure optimum fit -optical class 1 anti scratch & anti fog polycarbonate lens -field of view over 180° (panoramic) -high visibility lens enable the user to be seen in the dark & work in complete safety - light weight - glass colour :- white -conforms to EN 166.1.f -the goggles must be anti broken packing & canning in anti broken boxes for good long time store - Each proposal should attach with sample for testing, otherwise refused. <p>Origin :- general</p>



IT.	QTY	UNIT	VOCAB NO	DESCRIPTION
				HEAD PROTECTIVE. SAFETY HELMETS.
2.	100	Nos	162202/020.0	<p>Green safety helmet :</p> <p>1-the shell made of high density polyethylene (HDPE), provides superior impact protection.</p> <p>2-light weight</p> <p>3-high dielectric strength (440 V a. c)</p> <p>4-suspension system include front head band , with Cashion air sweatband , ratchet suspension , six – point Suspension.</p> <p>5-self – adjusting crown straps ensure a comfortable fit</p> <p>6-certified according :</p> <ul style="list-style-type: none"> . ANSI / ISEA Z 89.1-2009 (class C type I)or. . Europe <ul style="list-style-type: none"> ° certified according to EN 397 , with the following optional requirements : - lateral deformation (LD) -electrical insulation – 440 V AC -molten metal splash (MM) <p>7-approved to the following standards :</p> <ul style="list-style-type: none"> -EN 50365 – electrically insulating helmets for low voltage installations -EN 13463 -1- Use in potentially explosive atmosphere (ATEX) <p>8-each proposal should attach with sample for testing, otherwise refused.</p> <p>9- <u>origin:</u></p> <p>USA, Canada, European countries, Australia, South Korea, India.</p>

IT.	QTY	UNIT	VOCAB NO	DESCRIPTION
3.	1000	Nos	162202/035.0	<p>White safety helmet :</p> <p>1-the shell made of high density polyethylene (HDPE), provides superior impact protection.</p> <p>2-light weight.</p> <p>3-high dielectric strength (440 V a. c).</p> <p>4-suspension system include front head band , with Cashion air sweatband , ratchet suspension , six – point suspension</p> <p>5-self – adjusting crown straps ensure a comfortable fit</p> <p>6-certified according : .ANSI / ISEA Z 89 .1-2009 (class C , type I) or .Europe ° certified according to EN 397 , with the following</p> <p>Optional requirements :</p> <ul style="list-style-type: none"> - lateral deformation (LD) -Electrical insulation – 440 V AC -molten metal splash (MM) <p>7-approved to the following standards :</p> <ul style="list-style-type: none"> -EN 50365 – electrically insulating helmets for low voltage installations -EN 13463 -1 –Use in potentially explosive atmosphere (ATEX) <p>8-each proposal should attach with sample for testing, otherwise refused.</p> <p>9- <u>origin</u> : USA , Canada , European countries , Australia , south Korea, India.</p>

- Certificate of origin
- Mili certificate
- Third party inspection certificate (certify that all the equipment have inspected and certify that all materials are new ,unused and conforms to required specification, good off material, packing .

1-Lloyds Register

2-Bureau Veritas

3-Intertek Global

4-Tuv Rhenland

5-DNV

Delivery period (120) days

MINISTRY OF OIL
MIDLAND REFINERIES CO. (G.CO.)
(DAURA REFINERY)

ADVERTISEMENT
MIDLAND REFINERIES CO. ANNOUNCES FOR PURCHASING THE MATERIALS AS STATED BELOW:-

REQ.NO.	DESCRIPTION	QTY	ADVERTISEMENT NO.	BID BOND
1300/2017	GENERAL ELECTRICAL MATERIALS	2 ITEMS	ONCE	970 \$

1-The requisition to be sold in (250, 000) Iraqi dinars; un returnable or to transfer this amount to MRC Bank account number (90956)in Rafidan Bank head branch .

2-Technical and commercial offer should be opened at the same time, the representatives of the companies can be attend to our company (MRC) at 10 o'clock morning one day after the closing day stated below in item (28) .

3-Offered prices should be (CIP) Baghdad / Daura Refinery and preferred to be in us dollar. they will be final and nonnegotiable . (MRC) is not obliged to accept the lowest prices.

4-offeres (TECHNICAL & COMMERCIAL) to be submitted, separately in sealed envelopes, either directly at (MRC) reception bureau or sent by (DHL). the requisition number, the description and the closing date should be fixed on both envelopes. the validity of the offer should be mentioned within the technical offer ; also on the envelope of the commercial offer. offers sent by e- mail will be neglected.

5- The validity of the bid bond and the offer should be mentioned within both offers and should not be less than (120) days.

6- All pages of, both, the technical and commercial offers should be numbered in sequence, including the attachments and documents.

7-All documents (profile) (new establishment certificate stamped from the Iraqi embassy in your country financial statement accounts for the last two year (balance sheet) exemption letter issued from general commission for tax contain the taxes number and similar contracts achieved, issued by concerned contracting sides enclosed with the technical offer before purchasing the requisition.

8- A BID BOND OF AMOUNT THAT STATED IN THE ADVERTISEMENT ABOVE AGAINST EACH TENDER SHOULD BE SUBMITTED WITH COMMERCIAL OFFER FROM ONE OF THE PARTICIPANT IN THE COMPANY ACCORDING TO INSTRUCTION AS(LETTER OF GUARANTEE , CERTIFIED CHEQUE OR BILL OF EXCHANGE) (ORIGINAL COPY), ISSUED FROM :((HUDA BANK , ALBILAD ISLAMIC BANK FOR INVESTMENT AND FINANCE , TRADE BANK OF IRAQ , KURDISTAN INTERNATIONAL BANK FOR INVESTMENT AND DEVELOPMENT , ERBIL BANK , CIHAN BANK FOR ISLAMIC INVESTMENT AND FINANCE , NATIONAL ISLAMIC BANK , MANSOUR BANK FOR INVESTMENT , REGION FOR BUSINESS INVESTMENT AND FINANCING (EMERALD BANK BEFORE), BANK OF BAGHDAD , GULF COMMERCIAL BANK, SUMER COMMERCIAL BANK , CREDIT BANK OF IRAQ , NATIONAL BANK OF IRAQ , INVESTMENT BANK OF IRAQ , ASHUR INTERNATIONAL BANK FOR INVESTMENT , IRAQI ISLAMIC BANK FOR INVESTMENT AND DEVELOPMENT , INTERNATIONAL DEVELOPMENT BANK INVESTMENT AND FINANCE , COMMERCIAL BANK OF IRAQ , BYBLOS BANK , IRAQ IMDLEST BANK OF INVESTMENT , BANK MED , ISLAMIC REGIONAL COOPERATION BANK FOR DEVELOPMENT AND INVESTMENT)) AND RELEASED IMMEDIATELY IN CASE THE REQUISITION IS NOT AWARDED. OFFERS WITHOUT BID BOND WILL BE NEGLECTED . BID BOND ISSUED FROM ((ASIA BANK , DAR ESSALAAM INVESTMENT BANK , NORTH BANK FOR FINANCIAL AND INVESTMENT , DIJLAH AND FURAT BANK , WARKA BANK FOR INVESTMENT & FINANCE , THE BANK OF BASRAH INTERNATIONAL , UNITED BANK FOR INVESTMENT , ECONOMY FOR INVESTMENT AND FINANCE , UNION BANK OF IRAQ , ALRAWAHEL ISLAMIC INVESTMENT AND FINANCE BANK)) ARE NOT ACCEPTABLE . THIS BID BOND SHOULD BE VALID FOR NOT LESS THAN (120) DAYS (OFFERS WHICH CONTAIN BID BOND AS A SWIFT WILL BE NEGLECTED).

9- the delivery period (in days) should be, exactly specified.

10- Basic terms of payment is by irrevocable & unconfirmed letter of credit to be paid (100%) after the receipt of goods in baghdad complete and as ordered. other terms of payment may be, mutually, agreed upon later and for certain conditions, which are : a portion of the total amount to be paid, but against bank guarantee the prices of all offers are calculated according to the exchange rate of the central bank of iraq .at the date of opening the offers .for the purpose of preferability and by iraqi dinar only , for iraqi companies according to the exchange rate of the central bank of iraq at the date of preparing the contract,and the cost was stated in the contract.

11- Delay penalty to be applied with total amount, not exceeding (10%) of the total value of the contract .

12- An unconditional performance bond of (5%) of the total value of the contract to be submitted, from one of the participant in the company as a letter of guarantee (only) after the letter of award and before signing the contract according to instruction , from one of the banks mentioned in item (8) within (15) fifteen days from the date, the supplier is informed of the award. for any delay beyond the specified period, the award will be cancelled and the supplier will be considered as a shirker. the performance bond should be valid throughout the period of the contract or extending it upon extending the period of supply or until the guarantee period (if stated), is over. this performance bond will be released after the receipt of goods complete and as ordered and the supplier has fulfilled all his commitments regarding the contract otherwise, it will be confiscated by our company

- 13- (2.7%) of the total value of the contract to be deducted as taxes for iraqi companies. also, in case the payment is in iraqi dinar. for non-iraqi companies, the deducted amounts shall be transferred to the general commission of taxes within a period not exceeding (30) days from the date of completing the work and 3% for the contract contain onsite training , installation and operation not to pay the final payment to the second party and not to settle the final account unless after a written approval issued by the general commission for taxes, or deducting a percentage of 10% from it and sent it to the general commission for taxes before the release the final payment , whether the contract execution is in one payment or in multiple payments .
- 14- (0.003) off the total value of the contract to be deducted as stamp charges.
- 15- A sum of (205,000.00) id to be deducted as cost of import license.
- 16- Origin certificate should be approved by iraqi embassy/commercial attaché in the country of origin.
- 17- a sum of money in iraqi dinar for chemical materials to be deducted as an environmental cost after issuing the contract & will be determined by ministry of environment (for chemical materials only).
- 18- The participant has no right to omit or make any amendment, whatsoever, to any of the paragraphs of the requisition document.
- 19- The origin of the materials should be specified in the offer and fixed. and will not be changed for any reason and should be from the requested origin . State the method & the port of shipment & the entry point .
- 20- The supplier should state his full and fixed name and address
(Country , City , Street, Building, Email ,Phone NO.)
ALL offers and correspondences should be, clearly, signed by the general manager or whom is officially empowered via power of attorney. otherwise the offer will be neglected.
- 21- Third party inspection certificate should be provided from one of the following companies:
[LLOYDS REGISTER – BUREAU VERITAS - INTERTEK GLOBAL - TUV RHEINLAND - DNV]
- 22- It is necessary to present authorization letter from the manufacturer companies certified from ministry of foreign affairs or embassy or consulate or the commercial attached in country of origin (original copy)
(for tenders of specific materials)
- 23- The awarded supplier will bear the advertising fees value (150 \$) .
- 24- Iraqi laws are applied : the tender and the contract shall be governed and construed according to the iraqi law. courts shall have the exclusive jurisdiction to hear and determine all actions and proceedings arising out of the contract. governmental debts collection law (no. : 56), for the year 1977 shall be applied on amounts owed to (MRC).
- 25- For chemical (Req) the sample should be submitted with the technical & commercial offers before or (during)the closing otherwise the offers will be neglected
- 26- The contracted company shall not deal with Israel in any way ; otherwise , it shall bear all the legal consequences .
- 27-The companies that need any additional information in order to participate in any tender should buy the tender document & attached with their letters before closing date & our company shall state a date of conference for answering all questions in time not less than (7 day) before closing date
- 28- Closing date: 11 / 9 / 2017, till (1.00) o'clock (afternoon).**
- 29- All the procedure of the requirements governed by implementing Instructions of government contract No.2 for the Year 2014 , regulations and its amendments
Note: you can find the conditions of submitting offers on website: www.oil.gov.iq - www.mrc.oil.gov.iq

G. MANAGER

info@mrc.oil.gov.iq
purchase@mrc.oil.gov.iq

البريد الالكتروني لشركة مصافي الوسط

IT.	QT Y	UNI T	VOCAB NO.	DESCRIPTION
				GENERAL ELECTRICAL MATERIALS
				JOINTING
				HAWKER GLANDS MK II SERIES FOR P.V.C. CABLES WEATHER PROOF APPLICATION METEORIC SYSTEM 153 GLAND TYPE
1.	250	NOS	150571/002.2	GLAND REF NO.153/A 2.5-4 SQ. MM
				HAWKER GLAND & MK 11 SERIAL FOR FLAM PROOF APPLICATION METEORIC SYSTEM 453 GLAND TYPE.
2.	73	NOS	150571/014.2	GLAND REF NO.453/D 120-150 SQ. MM

ALL ORIGIN EXCEPT CHINESE

CERTIFICATE OF ORIGIN

MILL CERTIFICATE

THIRD PARTY INSPECTION CERTIFICATE: - WITNESSTEST

**(Lloyd's Register, Bureau Veritas,
Intertek Global, TUV Rhenland, DNV)**

DELIVER TIME : (90 DAYS)

MINISTRY OF OIL
MIDLAND REFINERIES CO. (G.CO.)
(DAURA REFINERY)

ADVERTISEMENT
MIDLAND REFINERIES CO. ANNOUNCES FOR PURCHASING THE MATERIALS AS STATED BELOW:-

REQ.NO.	DESCRIPTION	QTY	ADVERTISEMENT NO.	BID BOND
1307/2017	GENERAL SERVICES PARTS	8 ITEMS	TWICE	750 \$

1-The requisition to be sold in (250, 000) Iraqi dinars; un returnable or to transfer this amount to MRC Bank account number (90956)in Rafidan Bank head branch .

2-Technical and commercial offer should be opened at the same time, the representatives of the companies can be attend to our company (MRC) at 10 o'clock morning one day after the closing day stated below in item (28) .

3-Offered prices should be (CIP) Baghdad / Daura Refinery and preferred to be in us dollar. they will be final and nonnegotiable . (MRC) is not obliged to accept the lowest prices.

4-offeres (TECHNICAL & COMMERCIAL) to be submitted, separately in sealed envelopes, either directly at (MRC) reception bureau or sent by (DHL). the requisition number, the description and the closing date should be fixed on both envelopes. the validity of the offer should be mentioned within the technical offer ; also on the envelope of the commercial offer. offers sent by e- mail will be neglected.

5- The validity of the bid bond and the offer should be mentioned within both offers and should not be less than (120) days.

6- All pages of, both, the technical and commercial offers should be numbered in sequence, including the attachments and documents.

7-All documents (profile) (new establishment certificate stamped from the Iraqi embassy in your country financial statement accounts for the last two year (balance sheet) exemption letter issued from general commission for tax contain the taxes number and similar contracts achieved, issued by concerned contracting sides enclosed with the technical offer before purchasing the requisition.

8- A BID BOND OF AMOUNT THAT STATED IN THE ADVERTISEMENT ABOVE AGAINST EACH TENDER SHOULD BE SUBMITTED WITH COMMERCIAL OFFER FROM ONE OF THE PARTICIPANT IN THE COMPANY ACCORDING TO INSTRUCTION AS(LETTER OF GUARANTEE , CERTIFIED CHEQUE OR BILL OF EXCHANGE) (ORIGINAL COPY), ISSUED FROM :((HUDA BANK , ALBILAD ISLAMIC BANK FOR INVESTMENT AND FINANCE , TRADE BANK OF IRAQ , KURDISTAN INTERNATIONAL BANK FOR INVESTMENT AND DEVELOPMENT , ERBIL BANK , CIHAN BANK FOR ISLAMIC INVESTMENT AND FINANCE , NATIONAL ISLAMIC BANK , MANSOUR BANK FOR INVESTMENT , REGION FOR BUSINESS INVESTMENT AND FINANCING (EMERALD BANK BEFORE), BANK OF BAGHDAD , GULF COMMERCIAL BANK, SUMER COMMERCIAL BANK , CREDIT BANK OF IRAQ , NATIONAL BANK OF IRAQ , INVESTMENT BANK OF IRAQ , ASHUR INTERNATIONAL BANK FOR INVESTMENT , IRAQI ISLAMIC BANK FOR INVESTMENT AND DEVELOPMENT , INTERNATIONAL DEVELOPMENT BANK INVESTMENT AND FINANCE , COMMERCIAL BANK OF IRAQ , BYBLOS BANK , IRAQ IMDLEST BANK OF INVESTMENT , BANK MED , ISLAMIC REGIONAL COOPERATION BANK FOR DEVELOPMENT AND INVESTMENT)) AND RELEASED IMMEDIATELY IN CASE THE REQUISITION IS NOT AWARDED. OFFERS WITHOUT BID BOND WILL BE NEGLECTED . BID BOND ISSUED FROM ((ASIA BANK , DAR ESSALAAM INVESTMENT BANK , NORTH BANK FOR FINANCIAL AND INVESTMENT , DIJLAH AND FURAT BANK , WARKA BANK FOR INVESTMENT & FINANCE , THE BANK OF BASRAH INTERNATIONAL , UNITED BANK FOR INVESTMENT , ECONOMY FOR INVESTMENT AND FINANCE , UNION BANK OF IRAQ , ALRAWAHEL ISLAMIC INVESTMENT AND FINANCE BANK)) ARE NOT ACCEPTABLE . THIS BID BOND SHOULD BE VALID FOR NOT LESS THAN (120) DAYS (OFFERS WHICH CONTAIN BID BOND AS A SWIFT WILL BE NEGLECTED).

9- the delivery period (in days) should be, exactly specified.

10- Basic terms of payment is by irrevocable & unconfirmed letter of credit to be paid (100%) after the receipt of goods in baghdad complete and as ordered. other terms of payment may be, mutually, agreed upon later and for certain conditions, which are : a portion of the total amount to be paid, but against bank guarantee the prices of all offers are calculated according to the exchange rate of the central bank of iraq .at the date of opening the offers .for the purpose of preferability and by iraqi dinar only , for iraqi companies according to the exchange rate of the central bank of iraq at the date of preparing the contract,and the cost was stated in the contract.

11- Delay penalty to be applied with total amount, not exceeding (10%) of the total value of the contract .

12- An unconditional performance bond of (5%) of the total value of the contract to be submitted, from one of the participant in the company as a letter of guarantee (only) after the letter of award and before signing the contract according to instruction , from one of the banks mentioned in item (8) within (15) fifteen days from the date, the supplier is informed of the award. for any delay beyond the specified period, the award will be cancelled and the supplier will be considered as a shirker. the performance bond should be valid throughout the period of the contract or extending it upon extending the period of supply or until the guarantee period (if stated), is over. this performance bond will be released after the receipt of goods complete and as ordered and the supplier has fulfilled all his commitments regarding the contract otherwise, it will be confiscated by our company

- 13- (2.7%) of the total value of the contract to be deducted as taxes for iraqi companies. also, in case the payment is in iraqi dinar. for non-iraqi companies, the deducted amounts shall be transferred to the general commission of taxes within a period not exceeding (30) days from the date of completing the work and 3% for the contract contain onsite training , installation and operation not to pay the final payment to the second party and not to settle the final account unless after a written approval issued by the general commission for taxes, or deducting a percentage of 10% from it and sent it to the general commission for taxes before the release the final payment , whether the contract execution is in one payment or in multiple payments .
- 14- (0.003) off the total value of the contract to be deducted as stamp charges.
- 15- A sum of (205,000.00) id to be deducted as cost of import license.
- 16- Origin certificate should be approved by iraqi embassy/commercial attaché in the country of origin.
- 17- a sum of money in iraqi dinar for chemical materials to be deducted as an environmental cost after issuing the contract & will be determined by ministry of environment (for chemical materials only).
- 18- The participant has no right to omit or make any amendment, whatsoever, to any of the paragraphs of the requisition document.
- 19- The origin of the materials should be specified in the offer and fixed. and will not be changed for any reason and should be from the requested origin . State the method & the port of shipment & the entry point .
- 20- The supplier should state his full and fixed name and address
(Country , City , Street, Building, Email ,Phone NO.)
ALL offers and correspondences should be, clearly, signed by the general manager or whom is officially empowered via power of attorney. otherwise the offer will be neglected.
- 21- Third party inspection certificate should be provided from one of the following companies:
[LLOYDS REGISTER – BUREAU VERITAS - INTERTEK GLOBAL - TUV RHEINLAND - DNV]
- 22- It is necessary to present authorization letter from the manufacturer companies certified from ministry of foreign affairs or embassy or consulate or the commercial attached in country of origin (original copy)
(for tenders of specific materials)
- 23- The awarded supplier will bear the advertising fees value (150 \$) .
- 24- Iraqi laws are applied : the tender and the contract shall be governed and construed according to the iraqi law. courts shall have the exclusive jurisdiction to hear and determine all actions and proceedings arising out of the contract. governmental debts collection law (no. : 56), for the year 1977 shall be applied on amounts owed to (MRC).
- 25- For chemical (Req) the sample should be submitted with the technical & commercial offers before or (during)the closing otherwise the offers will be neglected
- 26- The contracted company shall not deal with Israel in any way ; otherwise , it shall bear all the legal consequences .
- 27-The companies that need any additional information in order to participate in any tender should buy the tender document & attached with their letters before closing date & our company shall state a date of conference for answering all questions in time not less than (7 day) before closing date
- 28- Closing date: 11 / 9 / 2017, till (1.00) o'clock (afternoon).**
- 29- All the procedure of the requirements governed by implementing Instructions of government contract No.2 for the Year 2014 , regulations and its amendments
Note: you can find the conditions of submitting offers on website: www.oil.gov.iq - www.mrc.oil.gov.iq

G. MANAGER

info@mrc.oil.gov.iq
purchase@mrc.oil.gov.iq

البريد الالكتروني لشركة مصافي الوسط

IT.	QT Y	UNI T	VOCAB NO.	DESCRIPTION
				GENEAL SERVICES PARTS.
				AUTOMATIC STRESS RELIEVES HEAT TREATMENT CONTROL CONSOLE 48 K" A FAN COOLED TRANSFORMER& 8- CHANNELED TOME U.P.S.R UNIT
1.	30	NOS	159068/028.3	ELASTIC STRAPS P/N 250/K
2.	25	NOS	159068/030.3	CERAMIC FIBER MATS SIZE 300 X 600 MM P/N209/A
3.	700	Mt	159068/053.3	SINGLE CORE CABLE C/W PLUG AND SOCKET
4.	812	MT	159068/054.3	THERMOCOUPLE WIRE TYPE K C/W PLUR AND SOCKET
5.	58	NOS	159068/058.3	FCP HEATING ELEMENT SIZE 405 X 125 MM
6.	26	NOS	159068/060.3	CERAMIC FIBER MAT 300MM* 300MM
7.	80	NOS	159068/070.3	SNAKE HEATER 60 VOLT 2.7 KW – CP 48 (1220 * 45 MM)
8.	22	NOS	091.3	16 MM² TRPLE CABLE SET 135 AMP 20 M IN LENGTH

ALL ORIGION EXCEPT CHINESE

CERTIFICATE OF ORIGIN

MILL CERTIFICATE

THIRD PARTY INSPECTION CERTIFICATE: - WITNESSTEST

(Lloyd's Register, Bureau Veritas,

Intertek Global, TUV Rhenland, DNV)

DELIVER TIME : (120 DAYS)

MINISTRY OF OIL
MIDLAND REFINERIES CO. (G.CO.)
(DAURA REFINERY)

ADVERTISEMENT
MIDLAND REFINERIES CO. ANNOUNCES FOR PURCHASING THE MATERIALS AS STATED BELOW:-

REQ.NO.	DESCRIPTION	QTY	ADVERTISEMENT NO.	BID BOND
1336/2017	INSTRUMENT & METERS	1 ITEM	ONCE	900 \$

1-The requisition to be sold in (250, 000) Iraqi dinars; un returnable or to transfer this amount to MRC Bank account number (90956)in Rafidan Bank head branch .

2-Technical and commercial offer should be opened at the same time, the representatives of the companies can be attend to our company (MRC) at 10 o'clock morning one day after the closing day stated below in item (28) .

3-Offered prices should be (CIP) Baghdad / Daura Refinery and preferred to be in us dollar. they will be final and nonnegotiable . (MRC) is not obliged to accept the lowest prices.

4-offeres (TECHNICAL & COMMERCIAL) to be submitted, separately in sealed envelopes, either directly at (MRC) reception bureau or sent by (DHL). the requisition number, the description and the closing date should be fixed on both envelopes. the validity of the offer should be mentioned within the technical offer ; also on the envelope of the commercial offer. offers sent by e- mail will be neglected.

5- The validity of the bid bond and the offer should be mentioned within both offers and should not be less than (120) days.

6- All pages of, both, the technical and commercial offers should be numbered in sequence, including the attachments and documents.

7-All documents (profile) (new establishment certificate stamped from the Iraqi embassy in your country financial statement accounts for the last two year (balance sheet) exemption letter issued from general commission for tax contain the taxes number and similar contracts achieved, issued by concerned contracting sides enclosed with the technical offer before purchasing the requisition.

8- A BID BOND OF AMOUNT THAT STATED IN THE ADVERTISEMENT ABOVE AGAINST EACH TENDER SHOULD BE SUBMITTED WITH COMMERCIAL OFFER FROM ONE OF THE PARTICIPANT IN THE COMPANY ACCORDING TO INSTRUCTION AS(LETTER OF GUARANTEE , CERTIFIED CHEQUE OR BILL OF EXCHANGE) (ORIGINAL COPY), ISSUED FROM :((HUDA BANK , ALBILAD ISLAMIC BANK FOR INVESTMENT AND FINANCE , TRADE BANK OF IRAQ , KURDISTAN INTERNATIONAL BANK FOR INVESTMENT AND DEVELOPMENT , ERBIL BANK , CIHAN BANK FOR ISLAMIC INVESTMENT AND FINANCE , NATIONAL ISLAMIC BANK , MANSOUR BANK FOR INVESTMENT , REGION FOR BUSINESS INVESTMENT AND FINANCING (EMERALD BANK BEFORE), BANK OF BAGHDAD , GULF COMMERCIAL BANK, SUMER COMMERCIAL BANK , CREDIT BANK OF IRAQ , NATIONAL BANK OF IRAQ , INVESTMENT BANK OF IRAQ , ASHUR INTERNATIONAL BANK FOR INVESTMENT , IRAQI ISLAMIC BANK FOR INVESTMENT AND DEVELOPMENT , INTERNATIONAL DEVELOPMENT BANK INVESTMENT AND FINANCE , COMMERCIAL BANK OF IRAQ , BYBLOS BANK , IRAQ IMDLEST BANK OF INVESTMENT , BANK MED , ISLAMIC REGIONAL COOPERATION BANK FOR DEVELOPMENT AND INVESTMENT)) AND RELEASED IMMEDIATELY IN CASE THE REQUISITION IS NOT AWARDED. OFFERS WITHOUT BID BOND WILL BE NEGLECTED . BID BOND ISSUED FROM ((ASIA BANK , DAR ESSALAAM INVESTMENT BANK , NORTH BANK FOR FINANCIAL AND INVESTMENT , DIJLAH AND FURAT BANK , WARKA BANK FOR INVESTMENT & FINANCE , THE BANK OF BASRAH INTERNATIONAL , UNITED BANK FOR INVESTMENT , ECONOMY FOR INVESTMENT AND FINANCE , UNION BANK OF IRAQ , ALRAWAHEL ISLAMIC INVESTMENT AND FINANCE BANK)) ARE NOT ACCEPTABLE . THIS BID BOND SHOULD BE VALID FOR NOT LESS THAN (120) DAYS (OFFERS WHICH CONTAIN BID BOND AS A SWIFT WILL BE NEGLECTED).

9- the delivery period (in days) should be, exactly specified.

10- Basic terms of payment is by irrevocable & unconfirmed letter of credit to be paid (100%) after the receipt of goods in baghdad complete and as ordered. other terms of payment may be, mutually, agreed upon later and for certain conditions, which are : a portion of the total amount to be paid, but against bank guarantee the prices of all offers are calculated according to the exchange rate of the central bank of iraq .at the date of opening the offers .for the purpose of preferability and by iraqi dinar only , for iraqi companies according to the exchange rate of the central bank of iraq at the date of preparing the contract,and the cost was stated in the contract.

11- Delay penalty to be applied with total amount, not exceeding (10%) of the total value of the contract .

12- An unconditional performance bond of (5%) of the total value of the contract to be submitted, from one of the participant in the company as a letter of guarantee (only) after the letter of award and before signing the contract according to instruction , from one of the banks mentioned in item (8) within (15) fifteen days from the date, the supplier is informed of the award. for any delay beyond the specified period, the award will be cancelled and the supplier will be considered as a shirker. the performance bond should be valid throughout the period of the contract or extending it upon extending the period of supply or until the guarantee period (if stated), is over. this performance bond will be released after the receipt of goods complete and as ordered and the supplier has fulfilled all his commitments regarding the contract otherwise, it will be confiscated by our company

- 13- (2.7%) of the total value of the contract to be deducted as taxes for iraqi companies. also, in case the payment is in iraqi dinar. for non-iraqi companies, the deducted amounts shall be transferred to the general commission of taxes within a period not exceeding (30) days from the date of completing the work and 3% for the contract contain onsite training , installation and operation not to pay the final payment to the second party and not to settle the final account unless after a written approval issued by the general commission for taxes, or deducting a percentage of 10% from it and sent it to the general commission for taxes before the release the final payment , whether the contract execution is in one payment or in multiple payments .
- 14- (0.003) off the total value of the contract to be deducted as stamp charges.
- 15- A sum of (205,000.00) id to be deducted as cost of import license.
- 16- Origin certificate should be approved by iraqi embassy/commercial attaché in the country of origin.
- 17- a sum of money in iraqi dinar for chemical materials to be deducted as an environmental cost after issuing the contract & will be determined by ministry of environment (for chemical materials only).
- 18- The participant has no right to omit or make any amendment, whatsoever, to any of the paragraphs of the requisition document.
- 19- The origin of the materials should be specified in the offer and fixed. and will not be changed for any reason and should be from the requested origin . State the method & the port of shipment & the entry point .
- 20- The supplier should state his full and fixed name and address
(Country , City , Street, Building, Email ,Phone NO.)
ALL offers and correspondences should be, clearly, signed by the general manager or whom is officially empowered via power of attorney. otherwise the offer will be neglected.
- 21- Third party inspection certificate should be provided from one of the following companies:
[LLOYDS REGISTER – BUREAU VERITAS - INTERTEK GLOBAL - TUV RHEINLAND - DNV]
- 22- It is necessary to present authorization letter from the manufacturer companies certified from ministry of foreign affairs or embassy or consulate or the commercial attached in country of origin (original copy)
(for tenders of specific materials)
- 23- The awarded supplier will bear the advertising fees value (150 \$) .
- 24- Iraqi laws are applied : the tender and the contract shall be governed and construed according to the iraqi law. courts shall have the exclusive jurisdiction to hear and determine all actions and proceedings arising out of the contract. governmental debts collection law (no. : 56), for the year 1977 shall be applied on amounts owed to (MRC).
- 25- For chemical (Req) the sample should be submitted with the technical & commercial offers before or (during)the closing otherwise the offers will be neglected
- 26- The contracted company shall not deal with Israel in any way ; otherwise , it shall bear all the legal consequences .
- 27-The companies that need any additional information in order to participate in any tender should buy the tender document & attached with their letters before closing date & our company shall state a date of conference for answering all questions in time not less than (7 day) before closing date
- 28- Closing date: 11 / 9 / 2017, till (1.00) o'clock (afternoon).**
- 29- All the procedure of the requirements governed by implementing Instructions of government contract No.2 for the Year 2014 , regulations and its amendments
Note: you can find the conditions of submitting offers on website: www.oil.gov.iq - www.mrc.oil.gov.iq

G. MANAGER

info@mrc.oil.gov.iq
purchase@mrc.oil.gov.iq

البريد الالكتروني لشركة مصافي الوسط

REQ.NO: 1336/2017

IT.	QTY	UNIT	VOCAB NO.	DESCRIPTION
				Instrument & Meters Location: New boiler / 11
1.	2	NOS	369977/123.3	PNEUMATIC SERVOMOTOR FOR AIR DAMPER <u>DOUBLE ACTING CYLINDER</u>: TYPE: SC/CP <u>DIAMETER</u>: 100mm <u>STROKE</u> :300mm <u>STEM MATER.:</u> CHROMATED STEEL <u>SERVICE</u> :CONTROL <u>SIGNAL FAILURE POSITION</u>: RETRACTED STEM <u>PNEUMATIC POSITIONER</u>: 55-IP5100-031NIIN <u>CONTROL SINGAL</u> :0.2 – 1bar REVERSIBLE <u>AIR SUPPLY</u>: NOR.:5bar , MAX.: 10 BAR <u>PNEUMATIC CONNECTION</u> : STAINLESS STEEL <u>LIMIT SWITCHES</u> : SPD, RATING2A, 24VDC,IP65 <u>CLASS</u>: ZONE2,GROUP IIC, TEMPERATURE T4 <u>PRESSURE GAUGE</u> : SUPPLY, INPUT, OUTPUT <u>MANUFACTURER</u> : SMC ITALIA

ORIGIN: EUROPE UNION– JAPAN – USA- Australia - Canada - South Korea.

Certificate of origin

Third party inspection certificate (visual test)

- 1.Lloyd s Register
2. Bureau Veritas
3. Intertek Global
4. TUV Rhenland
5. DNV

DELIVERY PERIODE : 90 DAYS

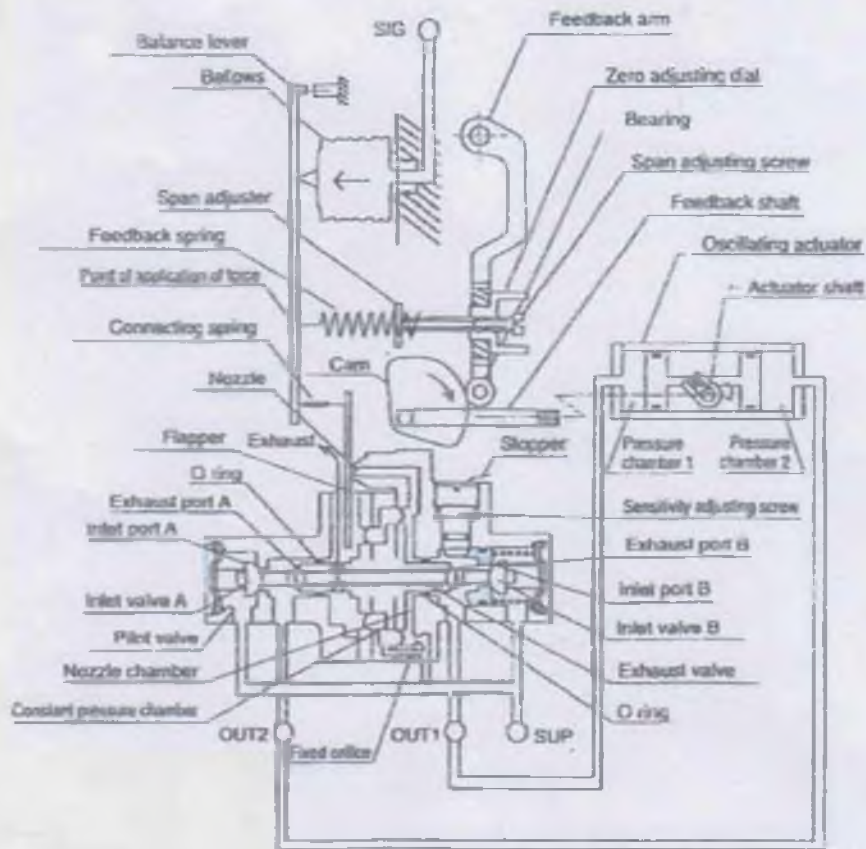

Counter operation is available by setting the cam back to front and connect pipings of OUT1 and OUT2 contrariwise (Use RA side for counter operation)

Fig.6 Drawing for IP5100 operation principle

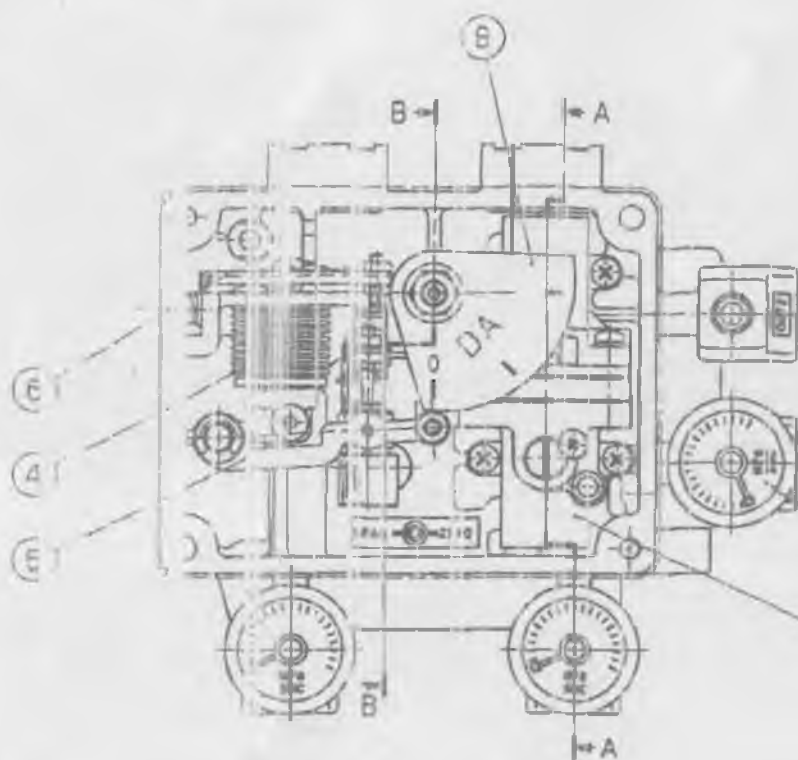

4-4

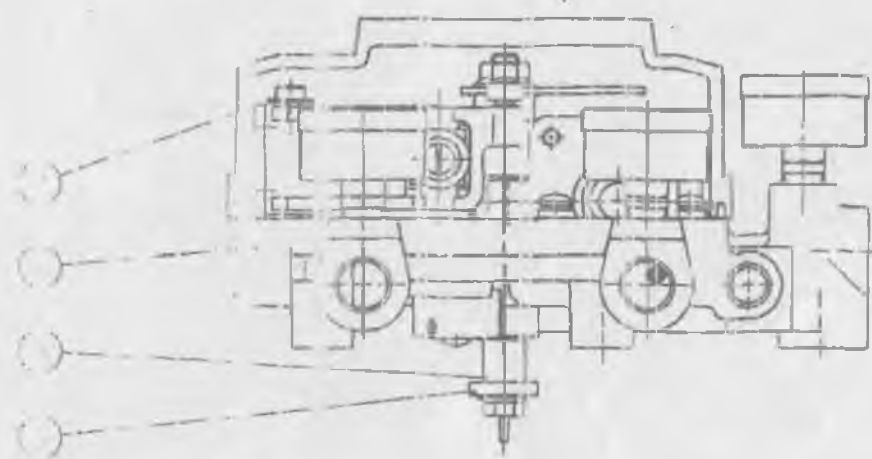

10	G33-※-01	Pressure gauge	—	3	
9	P368010-23	Fork pin unit	—	1	
8	P368010-18	Cam unit	—	1	
7	P378020-6	Feedback shaft assembly	—	1	
6	P378020-5	Balance lever unit	—	1	
5	P378020-4	Feedback arm unit	—	1	
4	P378010-8	Bellows assembly	—	1	
3	P378020-11	Pilot valve unit	—	1	
2	P378020-2	Body cover unit	—	1	(No opening degree indication panel)
1	P378020-1	Body unit	—	1	

10

3

Rotary type (No opening indication panel) construction

IP5100-※※0

MINISTRY OF OIL
MIDLAND REFINERIES CO. (G.CO.)
(DAURA REFINERY)

ADVERTISEMENT
MIDLAND REFINERIES CO. ANNOUNCES FOR PURCHASING THE MATERIALS AS STATED BELOW:-

REQ.NO.	DESCRIPTION	QTY	ADVERTISEMENT NO.	BID BOND
1602/2017	CERAMIC BALLS 1/2" INCH 12.5 MM	5000 KGS	TWICE	225 \$

1-The requisition to be sold in (250, 000) Iraqi dinars; un returnable or to transfer this amount to MRC Bank account number (90956)in Rafidan Bank head branch .

2-Technical and commercial offer should be opened at the same time, the representatives of the companies can be attend to our company (MRC) at 10 o'clock morning one day after the closing day stated below in item (28) .

3-Offered prices should be (CIP) Baghdad / Daura Refinery and preferred to be in us dollar. they will be final and nonnegotiable . (MRC) is not obliged to accept the lowest prices.

4-offeres (TECHNICAL & COMMERCIAL) to be submitted, separately in sealed envelopes, either directly at (MRC) reception bureau or sent by (DHL). the requisition number, the description and the closing date should be fixed on both envelopes. the validity of the offer should be mentioned within the technical offer ; also on the envelope of the commercial offer. offers sent by e- mail will be neglected.

5- The validity of the bid bond and the offer should be mentioned within both offers and should not be less than (120) days.

6- All pages of, both, the technical and commercial offers should be numbered in sequence, including the attachments and documents.

7-All documents (profile) (new establishment certificate stamped from the Iraqi embassy in your country financial statement accounts for the last two year (balance sheet) exemption letter issued from general commission for tax contain the taxes number and similar contracts achieved, issued by concerned contracting sides enclosed with the technical offer before purchasing the requisition.

8- A BID BOND OF AMOUNT THAT STATED IN THE ADVERTISEMENT ABOVE AGAINST EACH TENDER SHOULD BE SUBMITTED WITH COMMERCIAL OFFER FROM ONE OF THE PARTICIPANT IN THE COMPANY ACCORDING TO INSTRUCTION AS(LETTER OF GUARANTEE , CERTIFIED CHEQUE OR BILL OF EXCHANGE) (ORIGINAL COPY), ISSUED FROM :((HUDA BANK , ALBILAD ISLAMIC BANK FOR INVESTMENT AND FINANCE , TRADE BANK OF IRAQ , KURDISTAN INTERNATIONAL BANK FOR INVESTMENT AND DEVELOPMENT , ERBIL BANK , CIHAN BANK FOR ISLAMIC INVESTMENT AND FINANCE , NATIONAL ISLAMIC BANK , MANSOUR BANK FOR INVESTMENT , REGION FOR BUSINESS INVESTMENT AND FINANCING (EMERALD BANK BEFORE), BANK OF BAGHDAD , GULF COMMERCIAL BANK, SUMER COMMERCIAL BANK , CREDIT BANK OF IRAQ , NATIONAL BANK OF IRAQ , INVESTMENT BANK OF IRAQ , ASHUR INTERNATIONAL BANK FOR INVESTMENT , IRAQI ISLAMIC BANK FOR INVESTMENT AND DEVELOPMENT , INTERNATIONAL DEVELOPMENT BANK INVESTMENT AND FINANCE , COMMERCIAL BANK OF IRAQ , BYBLOS BANK , IRAQ IMDLEST BANK OF INVESTMENT , BANK MED , ISLAMIC REGIONAL COOPERATION BANK FOR DEVELOPMENT AND INVESTMENT)) AND RELEASED IMMEDIATELY IN CASE THE REQUISITION IS NOT AWARDED. OFFERS WITHOUT BID BOND WILL BE NEGLECTED . BID BOND ISSUED FROM ((ASIA BANK , DAR ESSALAAM INVESTMENT BANK , NORTH BANK FOR FINANCIAL AND INVESTMENT , DIJLAH AND FURAT BANK , WARKA BANK FOR INVESTMENT & FINANCE , THE BANK OF BASRAH INTERNATIONAL , UNITED BANK FOR INVESTMENT , ECONOMY FOR INVESTMENT AND FINANCE , UNION BANK OF IRAQ , ALRAWAHEL ISLAMIC INVESTMENT AND FINANCE BANK)) ARE NOT ACCEPTABLE . THIS BID BOND SHOULD BE VALID FOR NOT LESS THAN (120) DAYS (OFFERS WHICH CONTAIN BID BOND AS A SWIFT WILL BE NEGLECTED).

9- the delivery period (in days) should be, exactly specified.

10- Basic terms of payment is by irrevocable & unconfirmed letter of credit to be paid (100%) after the receipt of goods in baghdad complete and as ordered. other terms of payment may be, mutually, agreed upon later and for certain conditions, which are : a portion of the total amount to be paid, but against bank guarantee the prices of all offers are calculated according to the exchange rate of the central bank of iraq .at the date of opening the offers .for the purpose of preferability and by iraqi dinar only , for iraqi companies according to the exchange rate of the central bank of iraq at the date of preparing the contract,and the cost was stated in the contract.

11- Delay penalty to be applied with total amount, not exceeding (10%) of the total value of the contract .

12- An unconditional performance bond of (5%) of the total value of the contract to be submitted, from one of the participant in the company as a letter of guarantee (only) after the letter of award and before signing the contract according to instruction , from one of the banks mentioned in item (8) within (15) fifteen days from the date, the supplier is informed of the award. for any delay beyond the specified period, the award will be cancelled and the supplier will be considered as a shirker. the performance bond should be valid throughout the period of the contract or extending it upon extending the period of supply or until the guarantee period (if stated), is over. this performance bond will be released after the receipt of goods complete and as ordered and the supplier has fulfilled all his commitments regarding the contract otherwise, it will be confiscated by our company

- 13- (2.7%) of the total value of the contract to be deducted as taxes for iraqi companies. also, in case the payment is in iraqi dinar. for non-iraqi companies, the deducted amounts shall be transferred to the general commission of taxes within a period not exceeding (30) days from the date of completing the work and 3% for the contract contain onsite training , installation and operation not to pay the final payment to the second party and not to settle the final account unless after a written approval issued by the general commission for taxes, or deducting a percentage of 10% from it and sent it to the general commission for taxes before the release the final payment , whether the contract execution is in one payment or in multiple payments .
- 14- (0.003) off the total value of the contract to be deducted as stamp charges.
- 15- A sum of (205,000.00) id to be deducted as cost of import license.
- 16- Origin certificate should be approved by iraqi embassy/commercial attaché in the country of origin.
- 17- a sum of money in iraqi dinar for chemical materials to be deducted as an environmental cost after issuing the contract & will be determined by ministry of environment (for chemical materials only).
- 18- The participant has no right to omit or make any amendment, whatsoever, to any of the paragraphs of the requisition document.
- 19- The origin of the materials should be specified in the offer and fixed. and will not be changed for any reason and should be from the requested origin . State the method & the port of shipment & the entry point .
- 20- The supplier should state his full and fixed name and address
(Country , City , Street, Building, Email ,Phone NO.)
ALL offers and correspondences should be, clearly, signed by the general manager or whom is officially empowered via power of attorney. otherwise the offer will be neglected.
- 21- Third party inspection certificate should be provided from one of the following companies:
[LLOYDS REGISTER – BUREAU VERITAS - INTERTEK GLOBAL - TUV RHEINLAND - DNV]
- 22- It is necessary to present authorization letter from the manufacturer companies certified from ministry of foreign affairs or embassy or consulate or the commercial attached in country of origin (original copy)
(for tenders of specific materials)
- 23- The awarded supplier will bear the advertising fees value (150 \$) .
- 24- Iraqi laws are applied : the tender and the contract shall be governed and construed according to the iraqi law. courts shall have the exclusive jurisdiction to hear and determine all actions and proceedings arising out of the contract. governmental debts collection law (no. : 56), for the year 1977 shall be applied on amounts owed to (MRC).
- 25- For chemical (Req) the sample should be submitted with the technical & commercial offers before or (during)the closing otherwise the offers will be neglected
- 26- The contracted company shall not deal with Israel in any way ; otherwise , it shall bear all the legal consequences .
- 27-The companies that need any additional information in order to participate in any tender should buy the tender document & attached with their letters before closing date & our company shall state a date of conference for answering all questions in time not less than (7 day) before closing date
- 28- Closing date: 11 / 9 / 2017, till (1.00) o'clock (afternoon).**
- 29- All the procedure of the requirements governed by implementing Instructions of government contract No.2 for the Year 2014 , regulations and its amendments
Note: you can find the conditions of submitting offers on website: www.oil.gov.iq - www.mrc.oil.gov.iq

G. MANAGER

info@mrc.oil.gov.iq
purchase@mrc.oil.gov.iq

البريد الالكتروني لشركة مصافي الوسط

REQ: NO: 1602 / 2017

Ceramic Balls:

Physical Properties:

Colour	White
Shape	Spherical
Diameter	1/2" (12.5 mm)
Specific Density	2.3-2.4 g/cm ³
Crushing Strength	> 185 kgs/p
Maximum Temperature	1800 c °

Chemical Composition:

SiO ₂ Content	65 - 72%
Al ₂ O ₃	20 - 24%
SiO ₂ +Al ₂ O ₃	> 92%
Fe ₂ O ₂	0.4 - 0.8%

Note:

- Sample Should be submitted before closing date in order to complete laboratory evaluation test.

If sample not submitted , the offer will be neglected

- Origin : USA , Uk , Europe , Canada , south Korea , Australia , India

- Supply should be not more than (6 months)

-packing in 200 liter iron drum (1 drum = 250 kg)

(4 DRUMS PER PALLET)

Qty: 5000 kg

أعلان رقم (ب- ٢٨) لسنة ٢٠١٧

تعلن شركة مصافي الوسط عن اعلان الطلبات الاستيرادية كما مبين أدناه :-

REQ.NO.	DESCRIPTION	QTY	ADVERTISEMENT NO.	BID BOND
1609/2017	OXYGEN SCAVENGER -7780 OR EQUIVALENT	10 000 KGS	TWICE	750 \$

وبالشروط التالية :-

- ١- سيتم بيع مواصفات الطليبية بمبلغ ٢٥٠٠٠٠ (مئتان وخمسون الف) دينار عراقي غير قابل للرد او تحويل ذلك المبلغ الى المصروف الخاص لشركتنا (مصرف الرافدين) الفرع الرئيسي ورقم الحساب هو ٩٠٩٥٦
- ٢- سيتم فتح العروض الفنية والتجارية في ان واحد (في اليوم الذي يلي تاريخ الغلق) وفي حالة مصادفة عطلة توّجّل الى اليوم التالي وبالامكان حضور ممثلي الشركات الى مقر شركتنا عند الساعة العاشرة من اليوم الذي يلي تاريخ الغلق و المثبت في الفقرة (٢٨) ادناه
- ٣- يفضل تقديم الاسعار بعملة الدولار (CIP) واصل بغداد / شركة مصافي الوسط وتكون الاسعار نهائية وغير قابلة للتفاوض وشركتنا غير ملزمة بقبول أو طأ الاسعار.
- ٤- سيتم تقديم عرضين مغلقين (فني وتجاري) منفصلين مثبت عليهما رقم المناقصة وعنوانها وتاريخ الغلق وموقعين من قبل المدير العام أو المدير المفوض مع تثبيت الاسم الكامل وعليهما ختم الشركات في الصندوق الخاص في استعلامات شركتنا تقبل العروض التي ترسل مغلفة بالبريد أو D.H.L وتهمل العروض التي ترد بعد تاريخ الغلق أو عن طريق البريد الالكتروني.
- ٥- يجب تحديد فترة نفاذية العرض ضمن العرض الفني وكذلك توثيقها على الظرف الخاص بالعرض التجاري وكذلك تحديد تاريخ نفاذية التامينات الأولية في كلا العرضين ويجب ان لا تقل مدة نفاذ العروض عن (١٢٠ يوما).
- ٦- ترقيم كل صفحة من صفحات الططاء (الفني والتجاري) مع المرفقات.
- ٧- على الشركات الراغبة في المشاركة تقديم كافة المستمسكات الاصولية والقانونية الخاصة بالشركة (شهادة تاسيسية حديثة ونافاذة ومصدقة حسب الاصول من السفارة أو القنصلية العراقية في بلد الشركة – براءة ذمة صادرة من الهيئة العامة للضرائب تتضمن الرقم الضريبي – الموقف المالي متمثل بحسابات ختامية لأخر سنتين مالية – الهوية التجارية النافذة) مع تقديم الأعمال المماثلة صادرة من قبل جهات التعاقد المعنية قبل شراء الطليبية أو ترفق مع العرض الفني المقدم في حالة عدم تقديمها سابقاً
- ٨- يتم تقديم تامينات أولية وحسب المبالغ المثبتة امام كل طليبية في الاعلان اعلاه من قبل احد المساهمين في الشركة وحسب التعليمات وترفق مع العرض التجاري (خطاب ضمان او صك مصدق او سفتجة) نسخة اصلية صادرة من احد المصارف العراقية (مصرف الهدي ، البلاد الاسلامي للاستثمار والتمويل والمصرف العراقي للتجارة ، مصرف كوردستان الدولي للاستثمار والتنمية ، مصرف اربيل ، مصرف جيهان للاستثمار والتمويل ، الوطني الاسلامي ، المنصور للاستثمار ، الاقليم التجاري للاستثمار والتمويل (اميرالد سابقا) ، مصرف بغداد ، مصرف الخليج التجاري ، سومر التجاري ، الائتمان العراقي ، الاهلي العراقي ، الاستثمار العراقي ، اشور الدولي للاستثمار ، العراقي الاسلامي للاستثمار والتنمية ، التنمية الدولي للاستثمار والتمويل ، التجاري العراقي ، مصرف بيبيلوس اللبنياني ، مصرف الشرق الاوسط العراقي للاستثمار ، البحر المتوسط ، مصرف التعاون الاسلامي للاستثمار) وكافة فروع المصارف الاجنبية العاملة في العراق وترفق مع العرض التجاري وتطلق هذه التامينات في حالة عدم احوالة الطليبية عليكم وتهمل العروض التي لم ترفق بها التامينات الأولية. ترفض التامينات الأولية الصادرة من (بنك اسيا التركي ، دار السلام للاستثمار ، مصرف الشمال ، مصرف دجلة والفرات للتنمية والاستثمار و مصرف الوركاء للاستثمار والتمويل ومصرف البصرة الدولي و المصرف المتحد للاستثمار ومصرف الاقتصاد للاستثمار و التمويل ومصرف الاتحاد العراقي ، مصرف الرواحل الاسلامي للاستثمار والتمويل) ويجب ان تكون هذه التامينات نافذة لمدة لا تقل عن (١٢٠) يوما (تهمل العروض اذا كانت التامينات الأولية على شكل سويفت) .
- ٩- تحديد فترة التجهيز بالايام ولا يجوز تثبيت عبارة (من – الى) .
- ١٠- شروط الدفع/ اعتماد مستندي غير مثبت وغير قابل للنقض أو التحويل تطلق المستحقات (١٠٠ %) بعد استلام المواد كاملة ومطابقة للمواصفات في مصفى الدورة و يمكن الاتفاق على نسب أخرى مقابل كفاله مصرفيه ضامنه يتم احتساب اسعار جميع العطاءات لاغراض المفاضلة على اسس موحد و بموجب نشرة البنك المركز العراقي يوم الفتح ويكون الدفع بالدينار العراقي فقط للشركات العراقية ويتم احتساب الاسعار على اساس نشرة البنك المركزي العراقي ليوم اعداد العقد ويثبت المبلغ في العقد
- ١١- ترفض غرامة تاخيرية على المجهز لا يتجاوز حدها الأعلى نسبة ١٠ % من مبلغ عقد في حالة عدم تجهيز المواد بفترة التجهيز المثبتة في العقد.
- ١٢- تقدم التامينات النهائية على شكل خطاب ضمان حسن تنفيذ (حصرا) للعقد بنسبة (٥%) خمسة من المنة من مبلغ العقد بعد التبليغ بكتاب الاحالة وقيل توقيع العقد ومن احد المصارف الواردة في الفقرة رقم ٨ خلال مدة لا تتجاوز (١٥) يوما" وكشرط لتفعيل الاعتماد وفي حالة التأخر، تهمل الاحالة ويحال المجهز إلى لجنة الناقلين. وتبقى الكفالة نافذة لمدة العقد او تمديده عند تمديد فترة التجهيز او لحين انتهاء فتره الضمان، في حاله وجود (فترة ضمان) تطلق كفالة حسن الاداء بعد استلام المواد كاملة ومطابقة للمواصفات وبعد انجاز المجهز كافة التزامات المنصوصه في العقد وبخلافه سيتم مصادرتها من قبل شركتنا .
- ١٣- سيتم استقطاع نسبة (٢,٧ %) من قيمة العقد كضريبة وذلك بالنسبة للشركات العراقية وايضا في حالة الدفع بالدينار العراقي اما في حالة الشركات الغير عراقية فيتم حجز هذه النسبة كإمانات ضريبية وتطلق بعد ان يقوم المجهز بترويدنا ببراءة ذمة من الهيئة العامة للضرائب وبخلافه سيتم إحالة هذه الامانات إلى الهيئة العامة للضرائب خلال مدة لا تزيد عن (٣٠) يوم من تاريخ انجاز العمل وتكون النسبة ٣ % للعقود المتضمنة نصب واشراف موقعي ولا يتم صرف الدفعة الاخيرة للمقاولين والمتعاقدين وعدم تسوية الحساب النهائي للمقاول الاموافقة تحريرية من الهيئة العامة للضرائب او استقطاع مانسبته (١٠%) عشرة من المنة منها وارسالها الى الهيئة العامة للضرائب قبل اطلاق الدفعة الاخيرة سواء اكان تنفيذ العقد على دفعة واحدة ام على عدة دفعات .
- ١٤- تستقطع نسبة (٠,٠٠٣) من مبلغ العقد كرسوم طابع .
- ١٥- يستقطع مبلغ (٢٥٥٠٠٠) دينار عراقي من مبلغ العقد عن قيمة اجازة الاستيراد.
- ١٦- شهادة المنشأ يجب ان تكون مصدقة من قبل الملحقية التجارية العراقية أو السفارة في بلد المنشأ .
- ١٧- سيتم استقطاع مبلغ الاجور البيئية بعد اصدار العقد بموجب ما يتم تحديده من قبل وزارة البيئة (للمواد الكيماوية حصرا)
- ١٨- لا يجوز لمقدم الططاء شطب أي بند من بنود مستندات المناقصة أو إجراء أي تعديل فيها مهما كان نوعه .
- ١٩- منشأ المواد ينبغي ان يحدد في العرض ويكون من ضمن المنشأء المطلوبة وثابت (لن يتغير لأي سبب كان) مع تحديد طريقة وميناء الشحن منفذ الدخول .
- ٢٠- يقوم المجهز بتثبيت عنوانه الكامل (الدولة – المدينة – الشارع – البناية – العنوان البريدي والهاتف)و اسم المدير العام للشركة أو من يخولهم في العروض والمراسلات وبشكل واضح ورسمي وبخلافه يهمل العرض .

٢١- تقديم شهادة فحص طرف ثالث من إحدى الشركات التالية :

[LLOYD'S REGISTER – BUREAU VERITAS - INTERTEK GLOBAL - TUV RHEINLAND - DNV]

- ٢٢- تقديم كتاب تحويل من الشركات المصنعة مصدقة من وزارة الخارجية او السفارة او القنصلية او الملحقية التجارية في بلد المنشأ (نسخة اصليّة) وحسب التعليمات لطلبية (تجهيز المواد المتخصصة) .
- ٢٣- يتحمل من ترسو عليه المناقصة أجور نشر الإعلان مقدارها (١٥٠ دولار)
- ٢٤- تطبيق القوانين والتعليمات المعمول بها في العراق في حالة وقوع منازعات أو في كل ما لم يرد به نص ويكون النزاع خاضعاً لولاية القضاء العراقي مع تطبيق قانون تحصيل الديون الحكومية رقم ٥٦ لسنة ١٩٧٧ بأن المستحقات المالية تترتب لشركتنا بذمة الطرف الآخر .
- ٢٥- في طلبية المواد الكيماوية يجب ان تقدم النماذج خلال فترة الغلق (مع العروض الفنية والتجارية) وبخلافه سيتم اهمال العروض .
- ٢٦- عدم تعامل الشركة المتعاقد معها مع اسرائيل بأي شكل من الاشكال ، وبخلافه تتحمل كافة التبعات القانونية .
- ٢٧- يتوجب على الشركات التي ترغب بالمشاركة في اي طلبية والتي تطلب اي معلومات فنية شراء الطلبية ويتم ارفاق وصل الشراء مع الرسالة وقيل مدة مناسبة من تاريخ الغلق وستقوم شركتنا بتحديد تاريخ انعقاد المؤتمر الخاص بالاجابة عن استفسارات المشتركين في المناقصة وقيل موعد لايقبل عن (٧) ايام من تاريخ غلق المناقصة .
- ٢٨- تاريخ الغلق الساعة (١) بعد الظهر ليوم ٢٨ / ٨ / ٢٠١٧ .
- ٢٩- كافة الاجراءات لطلبية الشراء خاضعة لتعليمات تنفيذ العقود الحكومية رقم (٢) لسنة ٢٠١٤ والضوابط والتعديلات .

ملاحظة يمكن الاطلاع على شروط تقديم العطاءات وعلى الموقع الالكتروني :- www.oil.gov.iq
www.mrc.oil.gov.iq

----- مع التقدير

زيد كاظم شريف
المدير العام/ وكالة

REQ. NO: 1609/2017

**PURCHASING SPECIFICATIONS OF
(OXYGEN SCAVENGER) – 7780 OR EQUIVALENT**

- 1- A VOLATILE ALKALIZING OXYGEN SCAVENGER FOR BOTH WATER AND STEAM.
- 2- IT SHOULD FACILITATE PASSIVATION OF THE METAL SURFACE INSIDE THE CYLINDRICAL SHELL .
- 3- IT SHOULD CONTAIN NO HYDRAZINE .
- 4- IT MUST BE STABLE AT HIGH TEMPERATURES .
- 5- DOSING RATE TO BE DEFINED FOR OXYGEN REMOVAL FROM ABOUT 0.15 PPM TO 0.007 PPM .
- 6- SHELF LIFE SHOULD BE NOT LESS THAN 24 MONTH
- 7- IT MUST HAVE BEEN FIELD TESTED IN OUR PLANTS SUCCESSFULLY .
- 8- LAB PROCEDURES AND NECESSARY CHEMICAL REAGENTS AND APPARATUS FOR DETERMINING OXYGEN CONTENT AND THE RESIDUAL OF THE PRODUCT IN THE SAMPLES, AND CHEMICAL REAGENT FOR FERROUS IRON AND TOTAL IRON MUST BE OFFERED .
- 9- It should be organic

NOTE:

Offered material must be field successfully in boiler feed water.

**PAEKING: 200-220 KGS PE DRUMS MUST BE SEATED ON
PALLETS THAT CAN BE STACKED (4 DRUMS PER PALLET)**

Origin :- west Europe , America and Japan

MSDS :- Should be supply

Supply duration : 90 days

QTY: 10000 KGS

MINISTRY OF OIL
MIDLAND REFINERIES CO. (G.CO.)
(DAURA REFINERY)

ADVERTISEMENT
MIDLAND REFINERIES CO. ANNOUNCES FOR PURCHASING THE MATERIALS AS STATED BELOW:-

REQ.NO.	DESCRIPTION	QTY	ADVERTISEMENT NO.	BID BOND
1609/2017	OXYGEN SCAVENGER -7780 OR EQUIVALENT	10 000 KGS	TWICE	750 \$

1-The requisition to be sold in (250, 000) Iraqi dinars; un returnable or to transfer this amount to MRC Bank account number (90956)in Rafidan Bank head branch .

2-Technical and commercial offer should be opened at the same time, the representatives of the companies can be attend to our company (MRC) at 10 o'clock morning one day after the closing day stated below in item (28) .

3-Offered prices should be (CIP) Baghdad / Daura Refinery and preferred to be in us dollar. they will be final and nonnegotiable . (MRC) is not obliged to accept the lowest prices.

4-offeres (TECHNICAL & COMMERCIAL) to be submitted, separately in sealed envelopes, either directly at (MRC) reception bureau or sent by (DHL). the requisition number, the description and the closing date should be fixed on both envelopes. the validity of the offer should be mentioned within the technical offer ; also on the envelope of the commercial offer. offers sent by e- mail will be neglected.

5- The validity of the bid bond and the offer should be mentioned within both offers and should not be less than (120) days.

6- All pages of, both, the technical and commercial offers should be numbered in sequence, including the attachments and documents.

7-All documents (profile) (new establishment certificate stamped from the Iraqi embassy in your country financial statement accounts for the last two year (balance sheet) exemption letter issued from general commission for tax contain the taxes number and similar contracts achieved, issued by concerned contracting sides enclosed with the technical offer before purchasing the requisition.

8- A BID BOND OF AMOUNT THAT STATED IN THE ADVERTISEMENT ABOVE AGAINST EACH TENDER SHOULD BE SUBMITTED WITH COMMERCIAL OFFER FROM ONE OF THE PARTICIPANT IN THE COMPANY ACCORDING TO INSTRUCTION AS(LETTER OF GUARANTEE , CERTIFIED CHEQUE OR BILL OF EXCHANGE) (ORIGINAL COPY), ISSUED FROM :((HUDA BANK , ALBILAD ISLAMIC BANK FOR INVESTMENT AND FINANCE , TRADE BANK OF IRAQ , KURDISTAN INTERNATIONAL BANK FOR INVESTMENT AND DEVELOPMENT , ERBIL BANK , CIHAN BANK FOR ISLAMIC INVESTMENT AND FINANCE , NATIONAL ISLAMIC BANK , MANSOUR BANK FOR INVESTMENT , REGION FOR BUSINESS INVESTMENT AND FINANCING (EMERALD BANK BEFORE), BANK OF BAGHDAD , GULF COMMERCIAL BANK, SUMER COMMERCIAL BANK , CREDIT BANK OF IRAQ , NATIONAL BANK OF IRAQ , INVESTMENT BANK OF IRAQ , ASHUR INTERNATIONAL BANK FOR INVESTMENT , IRAQI ISLAMIC BANK FOR INVESTMENT AND DEVELOPMENT , INTERNATIONAL DEVELOPMENT BANK INVESTMENT AND FINANCE , COMMERCIAL BANK OF IRAQ , BYBLOS BANK , IRAQ IMDLEST BANK OF INVESTMENT , BANK MED , ISLAMIC REGIONAL COOPERATION BANK FOR DEVELOPMENT AND INVESTMENT)) AND RELEASED IMMEDIATELY IN CASE THE REQUISITION IS NOT AWARDED. OFFERS WITHOUT BID BOND WILL BE NEGLECTED . BID BOND ISSUED FROM ((ASIA BANK , DAR ESSALAAM INVESTMENT BANK , NORTH BANK FOR FINANCIAL AND INVESTMENT , DIJLAH AND FURAT BANK , WARKA BANK FOR INVESTMENT & FINANCE , THE BANK OF BASRAH INTERNATIONAL , UNITED BANK FOR INVESTMENT , ECONOMY FOR INVESTMENT AND FINANCE , UNION BANK OF IRAQ , ALRAWAHEL ISLAMIC INVESTMENT AND FINANCE BANK)) ARE NOT ACCEPTABLE . THIS BID BOND SHOULD BE VALID FOR NOT LESS THAN (120) DAYS (OFFERS WHICH CONTAIN BID BOND AS A SWIFT WILL BE NEGLECTED).

9- the delivery period (in days) should be, exactly specified.

10- Basic terms of payment is by irrevocable & unconfirmed letter of credit to be paid (100%) after the receipt of goods in baghdad complete and as ordered. other terms of payment may be, mutually, agreed upon later and for certain conditions, which are : a portion of the total amount to be paid, but against bank guarantee the prices of all offers are calculated according to the exchange rate of the central bank of iraq .at the date of opening the offers .for the purpose of preferability and by iraqi dinar only , for iraqi companies according to the exchange rate of the central bank of iraq at the date of preparing the contract,and the cost was stated in the contract.

11- Delay penalty to be applied with total amount, not exceeding (10%) of the total value of the contract .

12- An unconditional performance bond of (5%) of the total value of the contract to be submitted, from one of the participant in the company as a letter of guarantee (only) after the letter of award and before signing the contract according to instruction , from one of the banks mentioned in item (8) within (15) fifteen days from the date, the supplier is informed of the award. for any delay beyond the specified period, the award will be cancelled and the supplier will be considered as a shirker. the performance bond should be valid throughout the period of the contract or extending it upon extending the period of supply or until the guarantee period (if stated), is over. this performance bond will be released after the receipt of goods complete and as ordered and the supplier has fulfilled all his commitments regarding the contract otherwise, it will be confiscated by our company

- 13- (2.7%) of the total value of the contract to be deducted as taxes for iraqi companies. also, in case the payment is in iraqi dinar. for non-iraqi companies, the deducted amounts shall be transferred to the general commission of taxes within a period not exceeding (30) days from the date of completing the work and 3% for the contract contain onsite training , installation and operation not to pay the final payment to the second party and not to settle the final account unless after a written approval issued by the general commission for taxes, or deducting a percentage of 10% from it and sent it to the general commission for taxes before the release the final payment , whether the contract execution is in one payment or in multiple payments .
- 14- (0.003) off the total value of the contract to be deducted as stamp charges.
- 15- A sum of (205,000.00) id to be deducted as cost of import license.
- 16- Origin certificate should be approved by iraqi embassy/commercial attaché in the country of origin.
- 17- a sum of money in iraqi dinar for chemical materials to be deducted as an environmental cost after issuing the contract & will be determined by ministry of environment (for chemical materials only).
- 18- The participant has no right to omit or make any amendment, whatsoever, to any of the paragraphs of the requisition document.
- 19- The origin of the materials should be specified in the offer and fixed. and will not be changed for any reason and should be from the requested origin . State the method & the port of shipment & the entry point .
- 20- The supplier should state his full and fixed name and address
(Country , City , Street, Building, Email ,Phone NO.)
ALL offers and correspondences should be, clearly, signed by the general manager or whom is officially empowered via power of attorney. otherwise the offer will be neglected.
- 21- Third party inspection certificate should be provided from one of the following companies:
[LLOYDS REGISTER – BUREAU VERITAS - INTERTEK GLOBAL - TUV RHEINLAND - DNV]
- 22- It is necessary to present authorization letter from the manufacturer companies certified from ministry of foreign affairs or embassy or consulate or the commercial attached in country of origin (original copy)
(for tenders of specific materials)
- 23- The awarded supplier will bear the advertising fees value (150 \$) .
- 24- Iraqi laws are applied : the tender and the contract shall be governed and construed according to the iraqi law. courts shall have the exclusive jurisdiction to hear and determine all actions and proceedings arising out of the contract. governmental debts collection law (no. : 56), for the year 1977 shall be applied on amounts owed to (MRC).
- 25- For chemical (Req) the sample should be submitted with the technical & commercial offers before or (during)the closing otherwise the offers will be neglected
- 26- The contracted company shall not deal with Israel in any way ; otherwise , it shall bear all the legal consequences .
- 27-The companies that need any additional information in order to participate in any tender should buy the tender document & attached with their letters before closing date & our company shall state a date of conference for answering all questions in time not less than (7 day) before closing date
- 28- Closing date: 28 / 8 / 2017, till (1.00) o'clock (afternoon).**
- 29- All the procedure of the requirements governed by implementing Instructions of government contract No.2 for the Year 2014 , regulations and its amendments
Note: you can find the conditions of submitting offers on website: www.oil.gov.iq - www.mrc.oil.gov.iq

G. MANAGER

info@mrc.oil.gov.iq
purchase@mrc.oil.gov.iq

البريد الالكتروني لشركة مصافي الوسط

REQ. NO: 1609/2017

**PURCHASING SPECIFICATIONS OF
(OXYGEN SCAVENGER) – 7780 OR EQUIVALENT**

- 1- A VOLATILE ALKALIZING OXYGEN SCAVENGER FOR BOTH WATER AND STEAM.
- 2- IT SHOULD FACILITATE PASSIVATION OF THE METAL SURFACE INSIDE THE CYLINDRICAL SHELL .
- 3- IT SHOULD CONTAIN NO HYDRAZINE .
- 4- IT MUST BE STABLE AT HIGH TEMPERATURES .
- 5- DOSING RATE TO BE DEFINED FOR OXYGEN REMOVAL FROM ABOUT 0.15 PPM TO 0.007 PPM .
- 6- SHELF LIFE SHOULD BE NOT LESS THAN 24 MONTH
- 7- IT MUST HAVE BEEN FIELD TESTED IN OUR PLANTS SUCCESSFULLY .
- 8- LAB PROCEDURES AND NECESSARY CHEMICAL REAGENTS AND APPARATUS FOR DETERMINING OXYGEN CONTENT AND THE RESIDUAL OF THE PRODUCT IN THE SAMPLES, AND CHEMICAL REAGENT FOR FERROUS IRON AND TOTAL IRON MUST BE OFFERED .
- 9- It should be organic

NOTE:

Offered material must be field successfully in boiler feed water.

**PAEKING: 200-220 KGS PE DRUMS MUST BE SEATED ON
PALLETS THAT CAN BE STACKED (4 DRUMS PER PALLET)**

Origin :- west Europe , America and Japan

MSDS :- Should be supply

Supply duration : 90 days

QTY: 10000 KGS

تعلن شركة مصافي الوسط عن اعلان الطلبات الاستيرادية كما مبين أدناه :-

REQ.NO.	DESCRIPTION	QTY	ADVERTISEMENT NO.	BID BOND
3535/2017	3- PHASE INDUCTION MOTOR 8/4 HP . 3- PHASE INDUCTION MOTOR 75/37.5 HP.	2 ITEMS	TWICE	1500 \$

وبالشروط التالية :-

- ١- يتم بيع مواصفات الطلبية بمبلغ ٢٥٠٠٠٠ (مئتان وخمسون الف) دينار عراقي غير قابل للرد او تحويل ذلك المبلغ الى المصرف الخاص لشركتنا (مصرف الرافدين) الفرع الرئيسي ورقم الحساب هو ٩٠٩٥٦
- ٢- يتم فتح العروض الفنية والتجارية في ان واحد (في اليوم الذي يلي تاريخ العلق) وفي حالة مصادفة عطلة توصل الى اليوم التالي وبلا مكان حضور ممثلي الشركات الى مقر شركتنا عند الساعة العاشرة من اليوم الذي يلي تاريخ العلق و المئنت في الفقرة (٢٨) ادناه
- ٣- يفضل تقديم الاسعار بعملة الدولار (CIP) واصل بغداد / شركة مصافي الوسط وتكون الاسعار نهائية وغير قابلة للتفاوض وشركتنا غير ملزمة بقبول أو طأ الاسعار.
- ٤- يتم تقديم عرضين معلقين (فني وتجاري) منفصلين مثبت عليهما رقم المناقصة وعنوانها وتاريخ العلق وموقعين من قبل المدير العام أو المدير المفوض مع تثبيت الاسم الكامل وعليهما ختم الشركات في الصندوق الخاص في استعلامات شركتنا تقبل العروض التي ترسل مغلقة بالبريد أو D.H.L. وتهمل العروض التي ترد بعد تاريخ العلق أو عن طريق البريد الالكتروني.
- ٥- يجب تحديد فترة نفاذية العرض ضمن العرض الفني وكذلك تثبيتها على الظرف الخاص بالعرض التجاري وكذلك تحديد تاريخ نفاذية التامينات الأولية في كلا العرضين ويجب ان لا تقل مدة نفاذ العروض عن (١٢٠ يوما).
- ٦- ترقيم كل صفحة من صفحات العطاء (الفني والتجاري) مع المرفقات.
- ٧ - على الشركات الراغبة في المشاركة تقديم كافة المستمسكات الاصولية والقانونية الخاصة بالشركة (شهادة تأسيسية حديثة ونافذة ومصدقة حسب الاصول من السفارة أو القنصلية العراقية في بلد الشركة – براءة ذمة صادرة من الهيئة العامة للضرائب تتضمن الرقم الضريبي – الموقف المالي متمثل بحسابات ختامية لآخر سنتين مالية – الهوية التجارية النافذة) مع تقديم الاعمال المماتلة صادرة من قبل جهات التعاقد المعنية قبل شراء الطلبية أو ترفق مع العرض الفني المقدم في حالة عدم تقديمها سابقاً
- ٨- يتم تقديم تامينات أولية وحسب المبالغ المثبتة امام كل طلبية في الاعلان اعلاه من قبل احد المساهمين في الشركة وحسب التعليمات وترفق مع العرض التجاري (خطاب ضمان أو صك مصدق أو سفتجة) نسخة اصلية صادرة من احد المصارف العراقية (مصرف الهدى ، البلاد الاسلامي للاستثمار والتمويل ، المصرف العراقي للتجارة ، مصرف كوردستان الدولي للاستثمار والتنمية ، مصرف اربيل ، مصرف جيهان للاستثمار والتمويل ، الوطني الاسلامي ، المنصور للاستثمار ، الاقليم التجاري للاستثمار والتمويل (اميرالذ سابقا) ، مصرف بغداد ، مصرف الخليج التجاري ، سومر التجاري ، الائتمان العراقي ، الاهلي العراقي ، الاستثمار العراقي ، اشور الدولي للاستثمار ، العراقي الاسلامي للاستثمار والتنمية ، التنمية الدولي للاستثمار والتمويل ، التجاري العراقي ، مصرف بيبيلوس اللباني ، مصرف الشرق الاوسط العراقي للاستثمار ، البحر المتوسط ، مصرف التعاون الاسلامي للاستثمار) وكافة فروع المصارف الاجنبية العاملة في العراق وترفق مع العرض التجاري وتطلق هذه التامينات في حالة عدم احالة الطلبية عليكم وتهمل العروض التي لم ترفق بها التامينات الأولية. ترفض التامينات الأولية الصادرة من (بنك اسيا التركي ، دار السلام للاستثمار ، مصرف الشمال ، مصرف دجلة والفرات للتنمية والاستثمار و مصرف الوركاء للاستثمار والتمويل ومصرف البصرة الدولي و المصرف المتحد للاستثمار ومصرف الاقتصاد للاستثمار و التمويل ومصرف الاتحاد العراقي ، مصرف الرواحل الاسلامي للاستثمار والتمويل) ويجب ان تكون هذه التامينات نافذة لمدة لا تقل عن (١٢٠) يوما (تهمل العروض اذا كانت التامينات الأولية على شكل سويفت) .
- ٩- تحديد فترة التجهيز بالايام ولا يجوز تثبيت عبارة (من – الى) .
- ١٠- شروط الدفع/ اعتماد مستندي غير مثبت وغير قابل للنقض أو التحويل تطلق المستحقات (١٠٠ %) بعد استلام المواد كاملة ومطابقة للمواصفات في مصفى الدورة و يمكن الاتفاق على نسب أخرى مقابل كفاله مصرفيه ضامنه يتم احتساب اسعار جميع العطاءات لاغراض المفاضله على اسس موحده وبموجب نشرة البنك المركز العراقي يوم الفتح ويكون الدفع بالدينار العراقي فقط للشركات العراقية ويتم احتساب الاسعار على اساس نشرة البنك المركزي العراقي ليوم اعداد العقد ويثبت المبلغ في العقد
- ١١-تفرض غرامة تأخيرية على المجهز لايتجاوز حدھا الأعلى نسبة ١٠% من مبلغ عقد في حالة عدم تجهيز المواد بفترة التجهيز المثبتة في العقد.
- ١٢- تقدم التامينات النهائية على شكل خطاب ضمان حسن تنفيذ (حصرا) للعقد بنسبة (٥%) خمسة من المنة من مبلغ العقد بعد التبليغ بكتاب الاحالة وقبل توقيع العقد ومن احد المصارف الواردة في الفقرة رقم ٨ خلال مدة لا تتجاوز (١٥) يوما" وكشروط لتفعيل الاعتماد وفي حالة التأخر، تهمل الاحالة ويحال المجهز الى لجنة الناقلين. وتبقى الكفالة نافذة لمدة العقد او تمديده عند تمديد فترة التجهيز او لحين انتهاء فتره الضمان، في حاله وجود (فترة ضمان) تطلق كفالة حسن الاداء بعد استلام المواد كاملة ومطابقة للمواصفات وبعد انجاز المجهز كافة التزامات المنصوصه في العقد وبخلافه سيتم مصادرتها من قبل شركتنا .
- ١٣- سيتم استقطاع نسبة (٢.٧ %) من قيمة العقد كضريبة وذلك بالنسبة للشركات العراقية وايضا في حالة الدفع بالدينار العراقي اما في حالة الشركات الغير عراقية فيتم حجز هذه النسبة كإمانات ضريبية وتطلق بعد ان يقوم المجهز بترويدنا ببراءة ذمة من الهيئة العامة للضرائب وبخلافه سيتم إحالة هذه الامانات إلى الهيئة العامة للضرائب خلال مدة لا تزيد عن (٣٠) يوم من تاريخ انجاز العمل وتكون النسبة ٣% للعقود المتضمنة نصب واشراف موقعي ولايتم صرف الدفعة الاخيرة للمقاولين والمتعاقدين وعدم تسوية الحساب النهائي للمقاول الا بموافقة تحريرية من الهيئة العامة للضرائب او استقطاع مائسبته (١٠%) عشرة من المنة منها وارسالها الى الهيئة العامة للضرائب قبل اطلاق الدفعة الاخيرة سواء اكان تنفيذ العقد على دفعة واحدة ام على عدة دفعات .
- ١٤-تستقطع نسبة (٠.٠٠٣) من مبلغ العقد كرسوم طابع .
- ١٥-يستقطع مبلغ (٢٠٥٠٠٠) دينار عراقي من مبلغ العقد عن قيمة اجازة الاستيراد.
- ١٦-شهادة المنشأ يجب ان تكون مصدقة من قبل الملحقية التجارية العراقية أو السفارة في بلد المنشأ .
- ١٧-سيتم استقطاع مبلغ الاجور البيئية بعد اصدار العقد بموجب ما يتم تحديده من قبل وزارة البيئة (للمواد الكيماوية حصرا)
- ١٨-لا يجوز لمقدم العطاء شطب أي بند من بنود مستندات المناقصة أو إجراء أي تعديل فيها مهما كان نوعه .
- ١٩-منشأ المواد ينبغي ان يحدد في العرض ويكون من ضمن المنشأ المطلوبه وثابت (ان يتغير لأي سبب كان) مع تحديد طريقة وميناء الشحن منفذ الدخول .
- ٢٠- يقوم المجهز بتثبيت عنوانه الكامل (الدولة – المدينة – الشارع – البناية – العنوان البريدي والهاتف) و اسم المدير العام للشركة أو من يخولهم في العروض والمراسلات وبشكل واضح ورسمي وبخلافه يهمل العرض .

٢١- تقديم شهادة فحص طرف ثالث من إحدى الشركات التالية :

[LLOYD'S REGISTER – BUREAU VERITAS - INTERTEK GLOBAL - TUV RHEINLAND - DNV]

- ٢٢- تقديم كتاب تحويل من الشركات المصنعة مصدقة من وزارة الخارجية او السفارة او القنصلية او الملحقة التجارية في بلد المنشأ (نسخة اصادية) وحسب التعليمات لطلبات (تجهيز المواد المتخصصة) .
- ٢٣- يتحمل من ترسو عليه المناقصة أجور نشر الإعلان مقدارها (١٥٠ دولار)
- ٢٤- تطبيق القوانين والتعليمات المعمول بها في العراق في حالة وقوع منازعات أو في كل ما لم يرد به نص ويكون النزاع خاضعاً لولاية القضاء العراقي مع تطبيق قانون تحصيل الديون الحكومية رقم ٥٦ لسنة ١٩٧٧ بأن المستحقات المالية تترتب لشركتنا بذمة الطرف الآخر .
- ٢٥- في طلبات المواد الكيماوية يجب ان تقدم النماذج خلال فترة الغلق (مع العروض الفنية والتجارية) وبخلافه سيتم اهمال العروض .
- ٢٦- عدم تعامل الشركة المتعاقد معها مع اسرائيل باي شكل من الاشكال ، وبخلافه تتحمل كافة التبعات القانونية .
- ٢٧- يتوجب على الشركات التي ترغب بالمشاركة في اي طلبية والتي تطلب اي معلومات فنية شراء الطلبية ويتم ارفاق وصل الشراء مع الرسالة وقيل مدة مناسبة من تاريخ الغلق وستقوم شركتنا بتحديد تاريخ انعقاد المؤتمر الخاص بالاجابة عن استفسارات المشتركين في المناقصة وقيل موعد لايقبل عن (٧) ايام من تاريخ غلق المناقصة .
- ٢٨- تاريخ الغلق الساعة (١) بعد الظهر ليوم ٢٨ / ٨ / ٢٠١٧ .
- ٢٩- كافة الاجراءات لطلبات الشراء خاضعة لتعليمات تنفيذ العقود الحكومية رقم (٢) لسنة ٢٠١٤ والضوابط والتعديلات .

ملاحظة يمكن الاطلاع على شروط تقديم العطاءات وعلى الموقع الالكتروني :- www.oil.gov.iq
www.mrc.oil.gov.iq

----- مع التقدير

زيد كاظم شريف
المدير العام/ وكالة

REQ. NO. 3535/2017

Item no.	description	unit	Qty.
1	3-phase induction motor 8/4 HP 1500/750 RPM, 380V, 50HZ, EXDeIICT4, with IP 55,B5 mounting ,insulation class/temp rise F/B, ambient temp. 55C°.	Nos.	2
2	3-phase induction motor 75/37.5 HP 1500/750 RPM, 380V, 50HZ, EXDeIICT4, with IP 55,V3 mounting ,insulation class/temp rise F/B, ambient temp. 55C°.	Nos	1

Manufacture:-all origin except Chines

Note:- The dimensions for the above two items should be as the drawings attached.

1-Certificate of origin

2-Mill certificate

3- Dimensions check

4- Delivery period (180 days).

5-Third party inspection certificate witness test

- Lloyd's Register.
- Bureau Veritas
- Intertek Global.
- TUV Rhenland
- DNV.

عمل الحجوم ①

DESIGNED BY: OLR	HOWE-BAKER ENGINEERS, INC. SPECIFICATION SHEET	Tag No. V-201A&B
CHECKED:		GREASE CONTACTORS
DATE: E. 3-20-79	REVISION DATE: A 6-14-79 B C	Job No. J-864

FOR TO COMPLETE ALL INFORMATION MARKED SHEET 1 OF 1 VICE: GREASE PRODUCTION 2 REQ'D

DESIGN DATA			
OPERATING PRESSURE	PSIG	80	
OPERATING TEMPERATURE	°F	225	
LIQUID SPECIFIC GRAVITY		0.90	
CONTENTS LETHAL		YES (NO)	
DESIGN PRESSURE	PSIG	150 & 75 Int.	
DESIGN TEMPERATURE	°F	600 & 500 Top Head	
MAX ALL PRESS (COLD & NEW)	PSIG		
LIMITED BY			
HYDROSTATIC TEST	PSIG	YES	
SHELL HEADS CORR. ALLOW.	IN.	1/8	1/8
SHELL HEADS JOINT EFF.	%		
CODE: ASME SEC VIII, DIV 1	STAMP (YES) NO		
RADIOGRAPH: SPOT Expt. J&K	STRESS RELIEVE: YES, EXCEPT JACKET		
NATIONAL BOARD NO.			
INSULATION: YES, BY H-B	TYPE SUPPORTS LUGS		
FIREPROOFING: No			
SANDBLAST:	PAINT: Shop Primed		
MANHOLE (HINGED) DAYITED OTHER:			
PLATFORM CLIPS: LADDER CLIPS: INSUL. RINGS: Req'd.			
PIPE SUPPORTS:			
WIND LOAD:	SEISMIC:		
WT. EMPTY LB.	WT. FULL		
MATERIALS			
ITEM	THICKNESS	MAT'L CLASS	MAT'L. MINIMUM QUALITY
SHELL	IN.	C.S.	SA-515 Gr. 70 SA-386 Gr.
HEADS	IN.	C.S.	
LINING	IN.		
Hud. Hd.	IN.	C.S.	ASTM A-214 Gr. NCB
NOZZLE NECKS		C.S.	SA-106 Gr. B SMLS
FLANGES		C.S.	
COUPLING		C.S.	
M.H. COVER		C.S.	Lead pl. Type X lining cover
SUPPORTS		C.S.	
BOILTS/STUDS			
NUTS			
GASKETS			

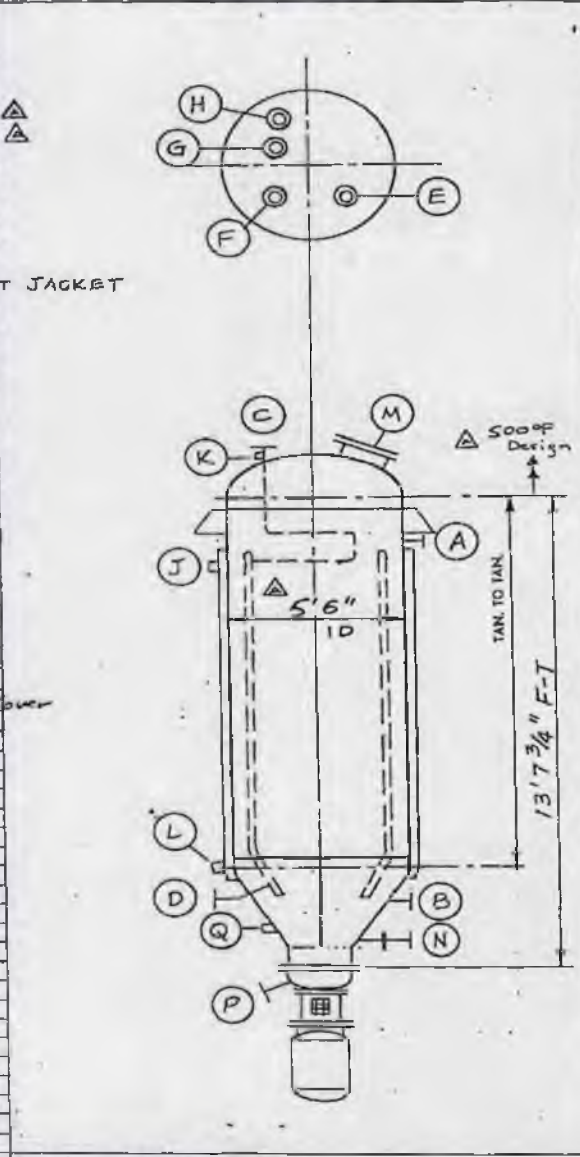

NOZZLE SCHEDULE						
SERVICE	MARK	NO.	SIZE	RATING	FACE	TYPE
HOT OIL IN	A	1	3	150	RF	WN
HOT OIL OUT	B	1	3	150	RF	WN
HOT OIL OUT	C	1	3	150	RF	WN
HOT OIL IN	D	1	3	150	RF	WN
RELIEF	E	1	4	150	RF	WN
FILL & RECYCLE	F	1	4	150	RF	WN
PRES. CON. VENT	G	1	1	300	RF	WN
VACUUM	H	1	4	150	RF	WN
JACKET VENT	J	1	3/4	6000	GRL	
VENT	K	1	3/4	6000	GRL	
JACKET DRAIN	L	1	1/2	3000	GRL	
MANWAY	M	1	1A	150	RF	SPCC
ADDITIVE INT.	N	1	1	300	RF	WN
PRODUCT OUT	O	1	4	150	RF	WN
TURBOWELL	P	1	1	6000	CDL	
	Q	1	1	6000	CDL	
	R	1	1	6000	CDL	

*NOZZLE TO BE PLUGGED OR BLINDED. FOR FURTHER DETAILS, SEE SHEET NO.

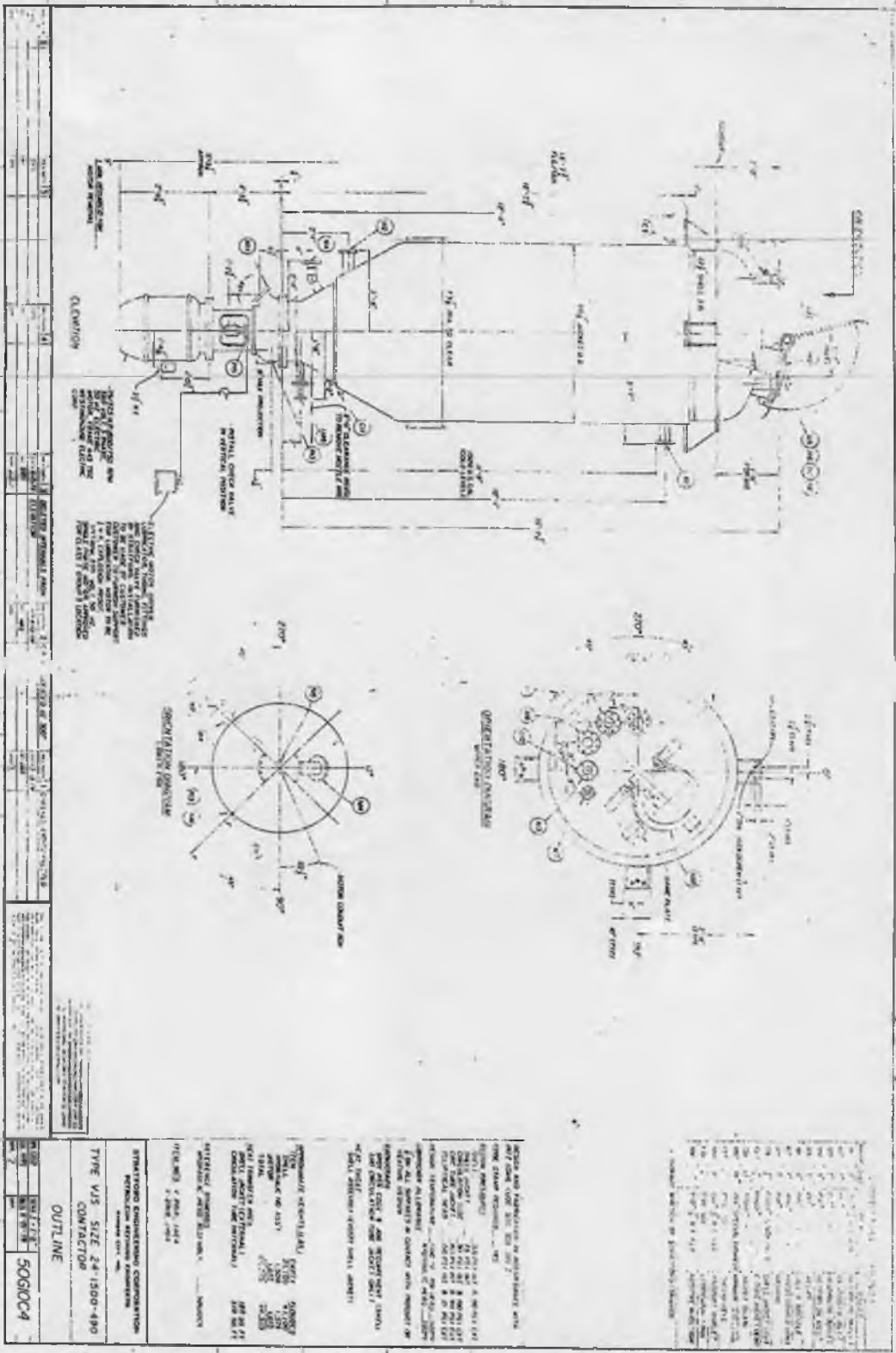

Rev 1.0
V.201

②

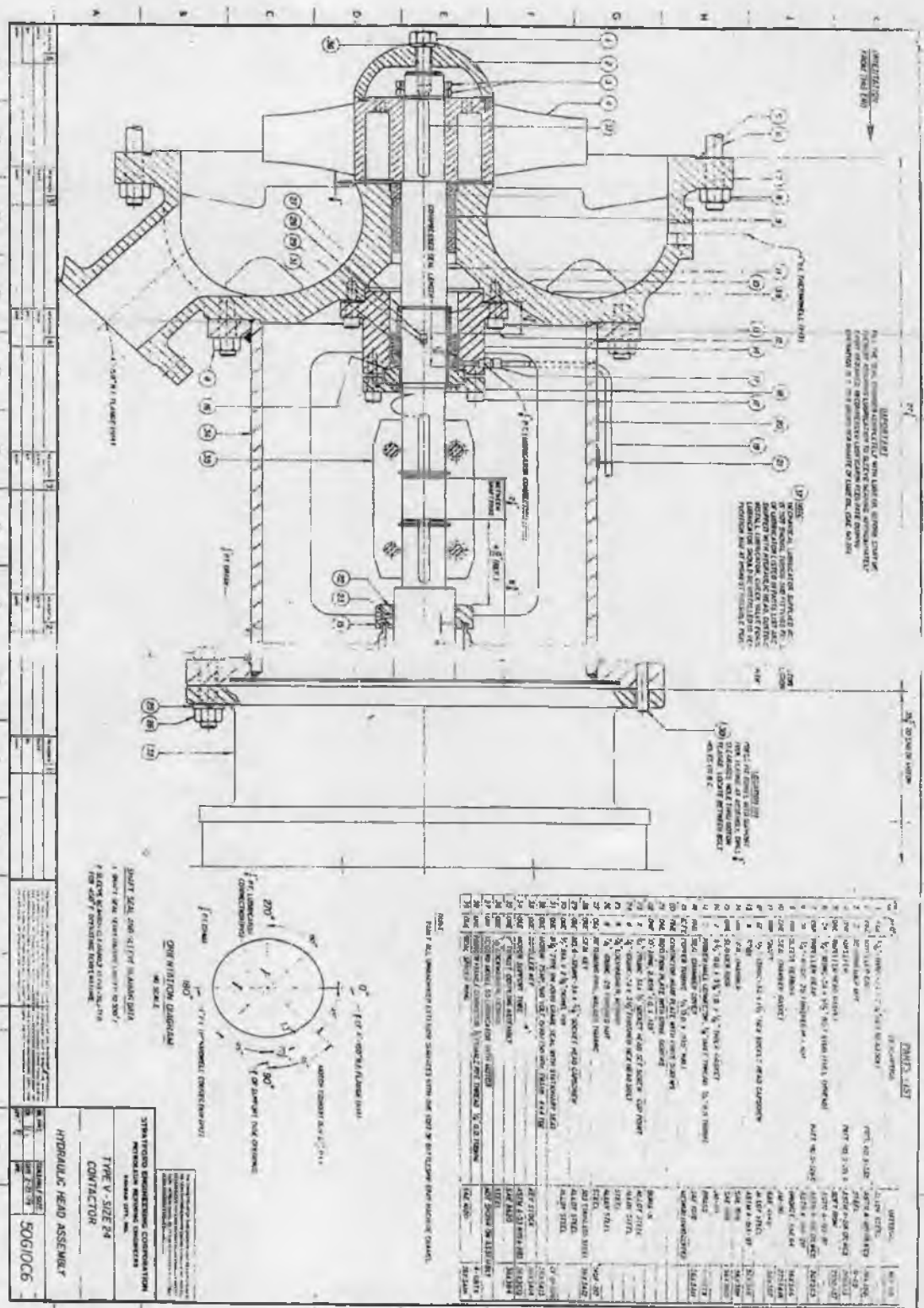

cool down
 1/201

③

جدد الصور
V 201

5

DRAWING TRANSMITTAL
FORM 31323C



Westinghouse Electric Corporation

CUSTOMER ORDER NO. 588 WESTINGHOUSE G.O. NO. KC-11898 MG FOR APPROVAL FOR CONSTRUCTION OR INSTALLATION

CUSTOMER STRATFORD-GRAHAM ENGRG. CORP. 4520 MADISON AVE KANSAS CITY MO 64111
 FROM STRATFORD - GRAHAM ENGRG. SAN JOSE, CAL 95112

MARK OF TAG V SZ 24 HEAD 57Z JOB 50G10

DESCRIPTION ITEM 1 SO # 79C60360

SQUIRREL CAGE WIND PROTECTION SILENT VOLTS AMPS

NUMBER OF PHASES 75/37.5 HWP 1465/735 FRAME 445TDZ NEMA DESIGN U

PHASE 3 WEIGHT 50 SIZE IN 380 FLA 104/84

INSULATION F F AMOUNT 40% FRAME WEIGHT 1.15 LRA 727/434

INSV AIRLINE AIRING GIRT FLANGE D KEEL YES NO DUTY 24-HOURS

TEMP PROOF TENV TPC AIR DRYER OTHER

TEMPERATURE CLASSIFICATION Y TAMPERS LOCKS

SPACE HEATERS none VOLTS WATTS

INTERNAL PROTECTION none

ADDITIONAL FEATURES

مدد الحسب
V201 ⑥

179060360

KCH 15 12 101

75/275
4/8
445722
TUEP
50
3

380
1415/735
108/24
727/34
247/200
200/

179060360	75	275
179060360	4	8
179060360	445	722
179060360	247	34
179060360	200	200
179060360	200	200
179060360	200	200
179060360	200	200
179060360	200	200
179060360	200	200

...

... 20



Westinghouse Electric Corporation
Medium Motor and Gearing Division
Buffalo, New York, U.S.A. 14240

Instruction Leaflet
2930-11TE

Page 1

ميدال الحوم
V 201



May, 1978
Supersedes I.L. 2930-11TD
dated July, 1976

Installation and Maintenance Instructions
For Life-Line T Motor, Frames 143T-449T

Medium Ac Motors

Receiving

1. Check Nameplate Data.
2. Turn shaft by hand to check that it turns freely.
3. Request "Receiving and Storage Instructions" for long-term storage indoors or any storage outdoors.
4. Lifting eyebolts are designed for raising the motor alone and should be removed after installing motor.

WARNING: The following safety precautions must be observed:

1. Electric rotating machinery and high voltage can cause serious or fatal injury if improperly installed, operated or maintained. Responsible personnel should be familiarized with NEMA MG2, safety standards for construction and guide for selection, installation and use of electric motors and generators, national electric code and all local safety requirements.
2. When servicing, all power sources to the motor and to the accessory devices should be de-energized and disconnected and all rotating parts should be at standstill.
3. Lifting means, when supplied, are intended for lifting the motor only. When two lifting devices are supplied with the motor a dual chain must be used.
4. Suitable protection must be used when working near machinery with high noise levels.
5. Safeguard or protective devices must not be by-passed or rendered inoperative.
6. The frame of this machine must be grounded in accordance with the National Electrical Code and applicable local codes.
7. Avoid contact with start or run capacitors in single-phase motors until a safe discharge procedure has been followed.
8. A suitable enclosure should be provided to prevent access to the motor by other than authorized personnel. Extra caution should be observed around motors that are automatically controlled or have automatic re-setting relays as they may restart unexpectedly.

9. Enclose all belts to prevent injury from broken belts.

10. Shaft key must be fully captive before motor is started.

11. Provide proper safeguards for personnel against possible failure of motor-mounted brake, particularly on applications involving over-hauling loads.

Location

1. Drip-proof motors are intended for use where atmosphere is relatively clean, dry, and non-corrosive. Keep windings clean with a soft brush, cloth or suction.

2. Totally enclosed motors may be installed where dirt, moisture and corrosion are present, or in outdoor locations. The drain plug in the end bracket must be removed periodically to drain accumulated condensation.

3. Explosion-proof motors are built for use in hazardous locations as indicated by Underwriters' label on the motor.

NOTE: In all cases, no surrounding structure should obstruct normal flow of ventilating air through or over the motor.

Installation

Fasten securely to a flat base with maximum size bolts. All ball or roller bearing normal thrust motors may be mounted in any position. Do not drive sheaves, couplings, sprockets or pinions on motor shaft.

Direct Drive

Align shafts accurately. If reverse rotation is detrimental to the driven device check rotation BEFORE connecting the motor to the load. See "start up."

V-Belt Drive

1. Mount motor sheave close to bearing housing.
2. Allow sufficient clearance for rotor end play.
3. Sheave diameter should not be less than NEMA recommended value. See NEMA MG1-14.42.

4. Align sheaves carefully, tighten belts only enough to prevent slippage.

Flange Motor

Fits are accurately machined to mate with driven equipment. Mating surfaces must be free of dirt or burrs and solidly engaged. The assembly should turn freely without stressing shaft and bearings from misalignment and thrust.

Electrical Connections

1. Connect motor per nameplate to correct power supply.
2. Install all wiring, fusing and grounding in accordance with National Electrical Code and local requirements.
3. Identify motor auxiliary devices such as space heaters or temperature sensors. Connect in proper circuits and insulate from motor power cables.

Wound Rotor Motors

a) Connect cables from secondary control to brushholder assembly. Bring cables through squeeze connector on front bracket, where provided.

b) Slip rings must be maintained smooth and true. Machine to restore proper surface for brushes.

c) Brushes must make good contact with slip rings along the whole face of brush. If needed, grind brushes in with fine sandpaper. Do not use lubricants. Service ports are provided for inspection of slip rings and brushes. Spring pressure is preset at about 1 lb. on 215-286T frames and 4 lbs. on 324-449T frames.

d) Must use same grade of brushes.

NOTE: Continuous light load operation can develop "threading" (fling grooving). Different brush grade may be required. Contact factory.

5061

S/S note

British Standard Flameproof Motors - Cage 'E' Range

50 Cycles - 650 Volts Maximum - Temperature Rise 65°C
THREE PHASE - Continuous Maximum Rating

H.P.	Frame	Full Load Speed r.p.m.	Full Load Amps on 400 V	Efficiency			Power Factor			Direct Starting % of Full Load		Star Delta Starting % of Full Load	
				1/1	2/3	1/2	1/1	2/3	1/2	Torque	Current	Torque	Current
20	E256	2920	27.0	89	88	87	81	80	88	230	700	70	230
	E204	1460	27.0	88	88	87	80	89	82	220	750	70	250
	E324	975	28.0	89	89	88	86	84	78	200	700	80	230
	E326	730	29.0	88	87	85	84	80	78	165	650	50	210
25	E284	2920	33.0	89	89	87	91	90	88	220	650	70	210
	E286	1460	34.0	89	89	88	90	89	85	180	650	55	210
	E326	975	35.0	90	89	88	86	81	76	200	700	60	230
	E364	730	35.0	91	91	90	84	83	75	180	650	55	210
30	E286	2920	40.0	89	89	87	91	90	88	220	650	70	210
	E324	1470	39.0	90	90	89	91	90	88	180	650	55	210
	E364	975	39.0	91	91	90	90	88	86	180	700	60	230
	E365	730	42.0	91	91	90	85	83	75	180	650	55	210
40	E324	2940	53.0	89	89	87	91	90	88	220	700	70	220
	E328	1470	52.0	91	91	90	91	90	88	180	650	55	210
	E365	975	52.0	91	91	90	90	88	85	165	650	50	210
	E404	730	54.0	92	91	90	86	84	80	165	620	50	200
50	E326	2940	66.0	89	89	87	92	91	90	220	700	70	220
	E364	1470	67.0	90	90	89	89	88	84	200	600	60	160
	E404	980	66.0	91	91	90	90	89	86	165	650	50	210
	E405	730	68.0	92	91	90	86	84	80	165	620	50	200
60	E365S	2950	77.0	89	88	86	94	93	92	165	750	50	240
	E365	1470	80.0	91	91	89	89	88	85	200	500	60	160
	E405	980	79.0	91	91	90	90	89	87	165	650	50	210
	E444	735	80.0	92	91	90	87	85	81	165	620	50	200
75	E404S	2950	95.0	90	89	86	94	93	92	165	680	50	220
	E404	1480	97.0	91	90	88	92	91	87	165	650	55	210
	E444	980	97.0	91	91	90	91	90	88	165	650	50	210
	E445	735	100.0	92	91	90	87	85	81	165	620	50	200
100	E405S	2950	126.0	91	90	88	94	93	92	165	680	50	220
	E405	1480	127.0	92	92	91	92	90	88	105	650	55	210
	E445	980	130.0	91	91	90	91	90	88	165	650	50	210
	E504	735	133.0	92	91	90	87	86	82	165	620	50	200
125	XE444S	2950	157.0	91	91	88	95	94	93	165	680	50	220
	XE444	1480	159.0	92	92	91	92	91	88	165	650	55	210
	E504	980	159.0	92	92	91	92	91	89	165	650	50	210
	E505	735	166.0	92	91	90	87	86	82	165	620	50	200
150	XE445S	2950	182.0	91	91	89	95	94	93	165	680	50	220
	XE445	1480	189.0	93	92	91	92	91	90	165	650	55	210
	E505	980	191.0	92	92	91	92	91	89	165	650	50	210
175	E504S	2950	215.0	92	91	90	95	94	93	165	680	50	220
	E504	1480	218.0	93	92	91	93	92	90	165	650	50	210
200	E505S	2950	246.0	92	91	90	95	94	93	165	680	50	220
	E505	1480	246.0	93	92	91	94	93	91	165	650	50	210

BROOK MOTORS LIMITED HUDDERSFIELD ENGLAND

Printed in England

3711/10/85

S/S rdg



M.301-5
Issue 1

PERFORMANCE DATA

British Standard Flameproof Motors - Cage 'E' Range

50 Cycles - 650 Volts Maximum - Temperature Rise 65°C
THREE PHASE - Continuous Maximum Rating

H.P.	Frame	Full Load Speed r.p.m.	Full Load Amps on 400 V	Efficiency			Power Factor			Direct Starting % of Full Load		Star Delta Starting % of Full Load	
				1/1	1/2	1/3	1/1	1/2	1/3	Torque	Current	Torque	Current
1/2	E162	950	1.15	70	68	63	67	59	47	220	480		
	E164	700	1.4	67	66	58	57	50	40	200	450		
3/4	E184	950	1.6	73	71	66	70	62	49	220	480		
	E182	710	2.0	75	73	68	54	45	34	240	400		
1	E162	1410	1.95	70	66	60	79	74	63	240	500		
	E182	950	2.1	75	75	69	68	61	51	220	450		
	E184	710	2.4	72	72	63	62	53	45	200	400		
1 1/2	E162	2840	2.6	75	74	69	84	75	64	300	650		
	E164	1410	2.7	73	71	57	82	77	66	240	550		
2	E164	2840	3.4	75	74	69	85	77	66	300	650		
	E182	1440	3.5	80	79	75	78	70	57	250	650		
	E184	950	3.8	78	78	76	73	65	56	220	500		
	E213	720	3.8	83	82	75	68	60	45	180	550		
3	E182	2880	4.3	83	82	78	90	87	77	230	700	70	230
	E184	1440	4.8	83	82	79	81	74	62	250	650	80	210
	E213	950	5.3	81	80	76	75	67	53	200	550	60	180
	E215	720	5.2	83	83	75	75	68	53	200	580	65	150
5	E184	2880	7.2	83	82	79	90	87	77	230	700	70	230
	E213	1440	7.7	85	84	83	82	79	72	210	620	65	200
	E215	960	8.4	84	81	78	76	72	50	200	550	65	180
	E254	720	8.4	84	84	82	76	71	60	170	500	50	150
7 1/2	E213	2900	10.5	86	85	82	90	89	84	230	700	70	230
	E215	1440	11.3	85	84	83	84	79	72	200	620	60	200
	E254	960	12.5	85	85	83	76	71	58	165	600	55	190
	E258	720	12.2	85	85	83	76	71	60	175	550	50	170
10	E215	2900	13.5	87	86	83	91	88	80	230	700	70	230
	E254	1440	14.2	86	86	85	88	86	81	200	650	60	210
	E256	960	15.3	85	85	83	83	78	68	210	700	65	220
	E284	725	16.2	86	86	84	77	71	60	175	550	55	170
12 1/2	E284	950	18.2	88	88	87	85	83	78	165	600	50	200
	E286	730	19.6	87	86	85	79	74	62	185	600	50	190
15	E254	2920	20.0	89	88	87	91		88	230	850	70	210
	E258	1450	21.0	87	87	86	88		81	200	650	60	210
	E286	970	21.0	89	89	88	86		74	170	620	55	200
	E324	730	23.0	87	86	83	80		64	165	600	50	200

القوة
التي
تنتجها
من
التي
تنتجها
من
القوة
التي
تنتجها
من
القوة
التي
تنتجها
من

ADVERTISEMENT
MIDLAND REFINERIES CO. ANNOUNCES FOR PURCHASING THE MATERIALS AS STATED BELOW:-

REQ.NO.	DESCRIPTION	QTY	ADVERTISEMENT NO.	BID BOND
3535/2017	3- PHASE INDUCTION MOTOR 8/4 HP . 3- PHASE INDUCTION MOTOR 75/37.5 HP.	2 ITEMS	TWICE	1500 \$

1-The requisition to be sold in (250, 000) Iraqi dinars; un returnable or to transfer this amount to MRC Bank account number (90956)in Rafidan Bank head branch .

2-Technical and commercial offer should be opened at the same time, the representatives of the companies can be attend to our company (MRC) at 10 o'clock morning one day after the closing day stated below in item (28) .

3-Offered prices should be (CIP) Baghdad / Daura Refinery and preferred to be in us dollar. they will be final and nonnegotiable . (MRC) is not obliged to accept the lowest prices.

4-offeres (TECHNICAL & COMMERCIAL) to be submitted, separately in sealed envelopes, either directly at (MRC) reception bureau or sent by (DHL). the requisition number, the description and the closing date should be fixed on both envelopes. the validity of the offer should be mentioned within the technical offer ; also on the envelope of the commercial offer. offers sent by e- mail will be neglected.

5- The validity of the bid bond and the offer should be mentioned within both offers and should not be less than (120) days.

6- All pages of, both, the technical and commercial offers should be numbered in sequence, including the attachments and documents.

7-All documents (profile) (new establishment certificate stamped from the Iraqi embassy in your country financial statement accounts for the last two year (balance sheet) exemption letter issued from general commission for tax contain the taxes number and similar contracts achieved, issued by concerned contracting sides enclosed with the technical offer before purchasing the requisition.

8- A BID BOND OF AMOUNT THAT STATED IN THE ADVERTISEMENT ABOVE AGAINST EACH TENDER SHOULD BE SUBMITTED WITH COMMERCIAL OFFER FROM ONE OF THE PARTICIPANT IN THE COMPANY ACCORDING TO INSTRUCTION AS(LETTER OF GUARANTEE , CERTIFIED CHEQUE OR BILL OF EXCHANGE) (ORIGINAL COPY), ISSUED FROM :((HUDA BANK , ALBILAD ISLAMIC BANK FOR INVESTMENT AND FINANCE , TRADE BANK OF IRAQ , KURDISTAN INTERNATIONAL BANK FOR INVESTMENT AND DEVELOPMENT , ERBIL BANK , CIHAN BANK FOR ISLAMIC INVESTMENT AND FINANCE , NATIONAL ISLAMIC BANK , MANSOUR BANK FOR INVESTMENT , REGION FOR BUSINESS INVESTMENT AND FINANCING (EMERALD BANK BEFORE), BANK OF BAGHDAD , GULF COMMERCIAL BANK, SUMER COMMERCIAL BANK , CREDIT BANK OF IRAQ , NATIONAL BANK OF IRAQ , INVESTMENT BANK OF IRAQ , ASHUR INTERNATIONAL BANK FOR INVESTMENT , IRAQI ISLAMIC BANK FOR INVESTMENT AND DEVELOPMENT , INTERNATIONAL DEVELOPMENT BANK INVESTMENT AND FINANCE , COMMERCIAL BANK OF IRAQ , BYBLOS BANK , IRAQ IMDLEST BANK OF INVESTMENT , BANK MED , ISLAMIC REGIONAL COOPERATION BANK FOR DEVELOPMENT AND INVESTMENT)) AND RELEASED IMMEDIATELY IN CASE THE REQUISITION IS NOT AWARDED. OFFERS WITHOUT BID BOND WILL BE NEGLECTED . BID BOND ISSUED FROM ((ASIA BANK , DAR ESSALAAM INVESTMENT BANK , NORTH BANK FOR FINANCIAL AND INVESTMENT , DIJLAH AND FURAT BANK , WARKA BANK FOR INVESTMENT & FINANCE , THE BANK OF BASRAH INTERNATIONAL , UNITED BANK FOR INVESTMENT , ECONOMY FOR INVESTMENT AND FINANCE , UNION BANK OF IRAQ , ALRAWAHEL ISLAMIC INVESTMENT AND FINANCE BANK)) ARE NOT ACCEPTABLE . THIS BID BOND SHOULD BE VALID FOR NOT LESS THAN (120) DAYS (OFFERS WHICH CONTAIN BID BOND AS A SWIFT WILL BE NEGLECTED).

9- the delivery period (in days) should be, exactly specified.

10- Basic terms of payment is by irrevocable & unconfirmed letter of credit to be paid (100%) after the receipt of goods in baghdad complete and as ordered. other terms of payment may be, mutually, agreed upon later and for certain conditions, which are : a portion of the total amount to be paid, but against bank guarantee the prices of all offers are calculated according to the exchange rate of the central bank of iraq .at the date of opening the offers .for the purpose of preferability and by iraqi dinar only , for iraqi companies according to the exchange rate of the central bank of iraq at the date of preparing the contract,and the cost was stated in the contract.

11- Delay penalty to be applied with total amount, not exceeding (10%) of the total value of the contract .

12- An unconditional performance bond of (5%) of the total value of the contract to be submitted, from one of the participant in the company as a letter of guarantee (only) after the letter of award and before signing the contract according to instruction , from one of the banks mentioned in item (8) within (15) fifteen days from the date, the supplier is informed of the award. for any delay beyond the specified period, the award will be cancelled and the supplier will be considered as a shirker. the performance bond should be valid throughout the period of the contract or extending it upon extending the period of supply or until the guarantee period (if stated), is over. this performance bond will be released after the receipt of goods complete and as ordered and the supplier has fulfilled all his commitments regarding the contract otherwise, it will be confiscated by our company

- 13- (2.7%) of the total value of the contract to be deducted as taxes for iraqi companies. also, in case the payment is in iraqi dinar. for non-iraqi companies, the deducted amounts shall be transferred to the general commission of taxes within a period not exceeding (30) days from the date of completing the work and 3% for the contract contain onsite training , installation and operation not to pay the final payment to the second party and not to settle the final account unless after a written approval issued by the general commission for taxes, or deducting a percentage of 10% from it and sent it to the general commission for taxes before the release the final payment , whether the contract execution is in one payment or in multiple payments .
- 14- (0.003) off the total value of the contract to be deducted as stamp charges.
- 15- A sum of (205,000.00) id to be deducted as cost of import license.
- 16- Origin certificate should be approved by iraqi embassy/commercial attaché in the country of origin.
- 17- a sum of money in iraqi dinar for chemical materials to be deducted as an environmental cost after issuing the contract & will be determined by ministry of environment (for chemical materials only).
- 18- The participant has no right to omit or make any amendment, whatsoever, to any of the paragraphs of the requisition document.
- 19- The origin of the materials should be specified in the offer and fixed. and will not be changed for any reason and should be from the requested origin . State the method & the port of shipment & the entry point .
- 20- The supplier should state his full and fixed name and address
(Country , City , Street, Building, Email ,Phone NO.)
ALL offers and correspondences should be, clearly, signed by the general manager or whom is officially empowered via power of attorney. otherwise the offer will be neglected.
- 21- Third party inspection certificate should be provided from one of the following companies:
[LLOYDS REGISTER – BUREAU VERITAS - INTERTEK GLOBAL - TUV RHEINLAND - DNV]
- 22- It is necessary to present authorization letter from the manufacturer companies certified from ministry of foreign affairs or embassy or consulate or the commercial attached in country of origin (original copy)
(for tenders of specific materials)
- 23- The awarded supplier will bear the advertising fees value (150 \$) .
- 24- Iraqi laws are applied : the tender and the contract shall be governed and construed according to the iraqi law. courts shall have the exclusive jurisdiction to hear and determine all actions and proceedings arising out of the contract. governmental debts collection law (no. : 56), for the year 1977 shall be applied on amounts owed to (MRC).
- 25- For chemical (Req) the sample should be submitted with the technical & commercial offers before or (during)the closing otherwise the offers will be neglected
- 26- The contracted company shall not deal with Israel in any way ; otherwise , it shall bear all the legal consequences .
- 27-The companies that need any additional information in order to participate in any tender should buy the tender document & attached with their letters before closing date & our company shall state a date of conference for answering all questions in time not less than (7 day) before closing date
- 28- Closing date: 28 / 8 / 2017, till (1.00) o'clock (afternoon).**
- 29- All the procedure of the requirements governed by implementing Instructions of government contract No.2 for the Year 2014 , regulations and its amendments
Note: you can find the conditions of submitting offers on website: www.oil.gov.iq - www.mrc.oil.gov.iq

G. MANAGER

info@mrc.oil.gov.iq
purchase@mrc.oil.gov.iq

البريد الالكتروني لشركة مصافي الوسط

REQ. NO. 3535/2017

Item no.	description	unit	Qty.
1	3-phase induction motor 8/4 HP 1500/750 RPM, 380V, 50HZ, EXDeIICT4, with IP 55,B5 mounting ,insulation class/temp rise F/B, ambient temp. 55C°.	Nos.	2
2	3-phase induction motor 75/37.5 HP 1500/750 RPM, 380V, 50HZ, EXDeIICT4, with IP 55,V3 mounting ,insulation class/temp rise F/B, ambient temp. 55C°.	Nos	1

Manufacture:-all origin except Chines

Note:- The dimensions for the above two items should be as the drawings attached.

1-Certificate of origin

2-Mill certificate

3- Dimensions check

4- Delivery period (180 days).

5-Third party inspection certificate witness test

- Lloyd's Register.
- Bureau Veritas
- Intertek Global.
- TUV Rhenland
- DNV.

عمل الحجوم ①

DESIGNED BY: OLR	HOWE-BAKER ENGINEERS, INC. SPECIFICATION SHEET	Tag No. V-201A&B
CHECKED:		GREASE CONTACTORS
DATE: E. 3-20-79	REVISION DATE: A 6-14-79 B C	Job No. J-864

FOR TO COMPLETE ALL INFORMATION MARKED SHEET 1 OF 1 VICE: GREASE PRODUCTION 2 REQ'D

DESIGN DATA			
OPERATING PRESSURE	PSIG	80	
OPERATING TEMPERATURE	°F	225	
LIQUID SPECIFIC GRAVITY		0.90	
CONTENTS LETHAL		YES (NO)	
DESIGN PRESSURE	PSIG	150 & 75 Int.	
DESIGN TEMPERATURE	°F	600 & 500 Top Head	
MAX ALL PRESS (COLD & NEW)	PSIG		
LIMITED BY			
HYDROSTATIC TEST	PSIG	YES	
SHELL HEADS CORR. ALLOW.	IN.	1/16	1/16
SHELL HEADS JOINT EFF.	%		
CODE: ASME SEC VIII, DIV I		STAMP (YES) NO	
RADIOGRAPH: SPOT Expt. J&K		STRESS RELIEVE: YES, EXCEPT JACKET	
NATIONAL BOARD NO.			
INSULATION: YES, BY H-B		TYPE SUPPORTS: LUGS	
FIREPROOFING: No			
SANDBLAST:		PAINT: Shop Primed	
MANHOLE (HINGED) DAYITED OTHER:			
PLATFORM CLIPS: LADDER CLIPS: INSUL. RINGS: Req'd.			
PIPE SUPPORTS:			
WIND LOAD: SEISMIC:			
WT. EMPTY LB. WT. FULL			
MATERIALS			
ITEM	THICKNESS	MAT'L CLASS	MAT'L. MINIMUM QUALITY
SHELL	IN.	C.S.	SA-515 Gr. 70 SA-354 Gr.
HEADS	IN.	C.S.	
LINING	IN.		
Head Hd.	IN.	C.S.	ASTM A-214 Gr. NCB
	IN.		
NOZZLE NECKS		C.S.	SA-106 Gr. B SMLS
FLANGES		C.S.	
COUPLING		C.S.	
M.H. COVER		C.S.	Lead pt. Type & lining cover
SUPPORTS		C.S.	
BOILTS/STUDS			
NUTS			
GASKETS			

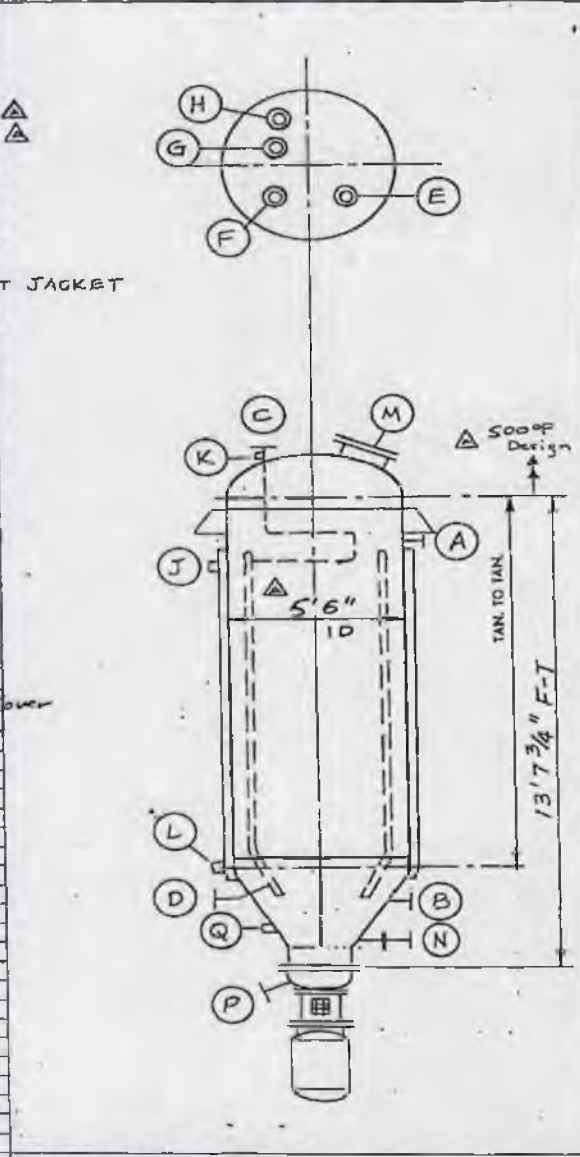

NOZZLE SCHEDULE						
SERVICE	MARK	NO.	SIZE	RATING	FACE	TYPE
HOT OIL IN	A	1	3	150	RF	WN
HOT OIL OUT	B	1	3	150	RF	WN
HOT OIL OUT	C	1	3	150	RF	WN
HOT OIL IN	D	1	3	150	RF	WN
RELIEF	E	1	4	150	RF	WN
FILL & RECYCLE	F	1	4	150	RF	WN
PRES. CON. VENT	G	1	1	300	RF	WN
VACUUM	H	1	4	150	RF	WN
JACKET VENT	J	1	3/4	6000	GR	PL
VENT	K	1	3/4	6000	GR	PL
JACKET DRAIN	L	1	1/2	3000	GR	PL
MANWAY	M	1	1A	150	RF	SPCC
ADDITIVE INT.	N	1	1	300	RF	WN
PRODUCT OUT	P	1	4	150	RF	WN
TURBOWELL	Q	1	1	6000	GR	PL
	R	1	1	6000	GR	PL

*NOZZLE TO BE PLUGGED OR BLINDED. FOR FURTHER DETAILS, SEE SHEET NO.

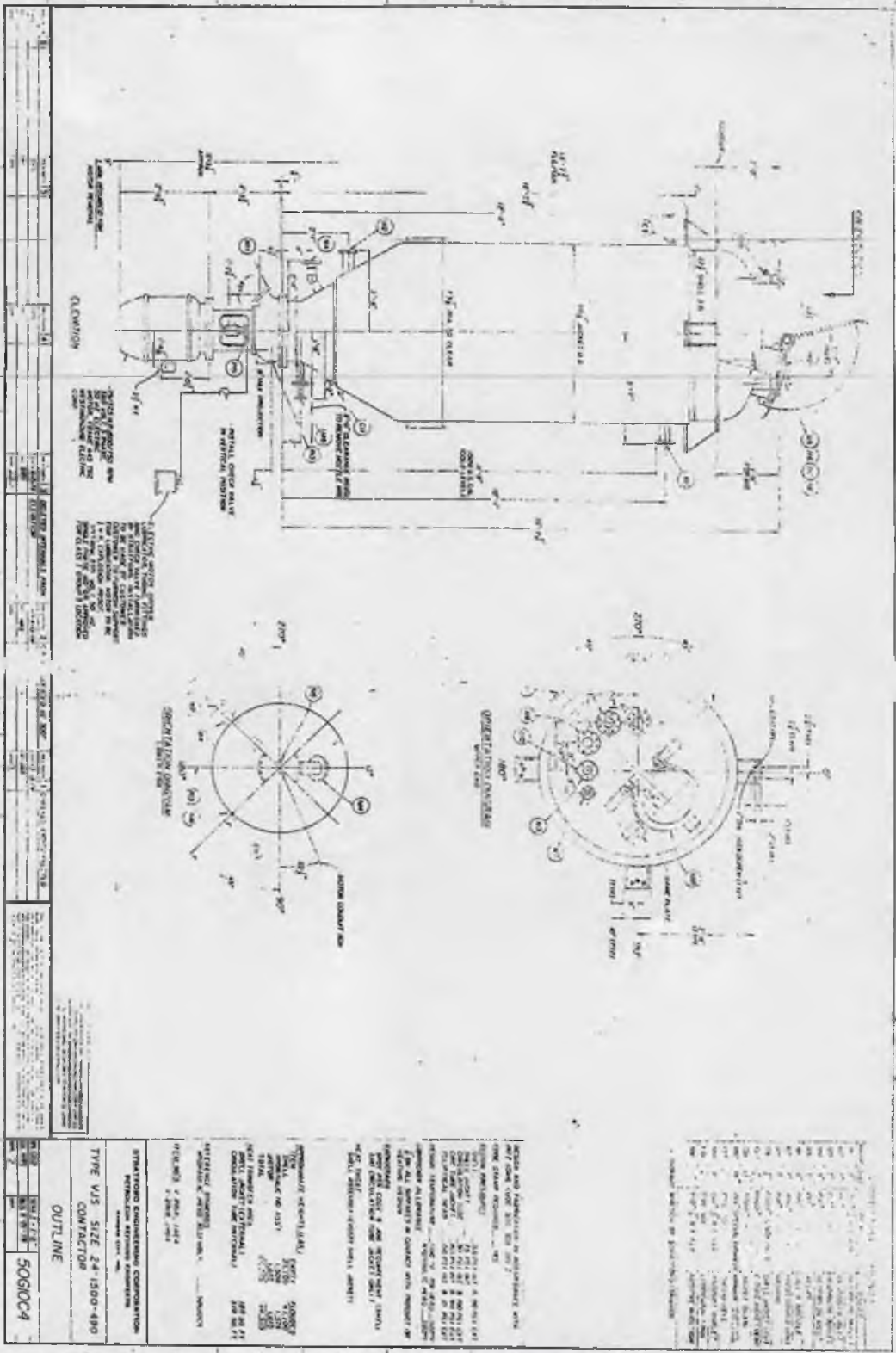

Rev 11/2001

②

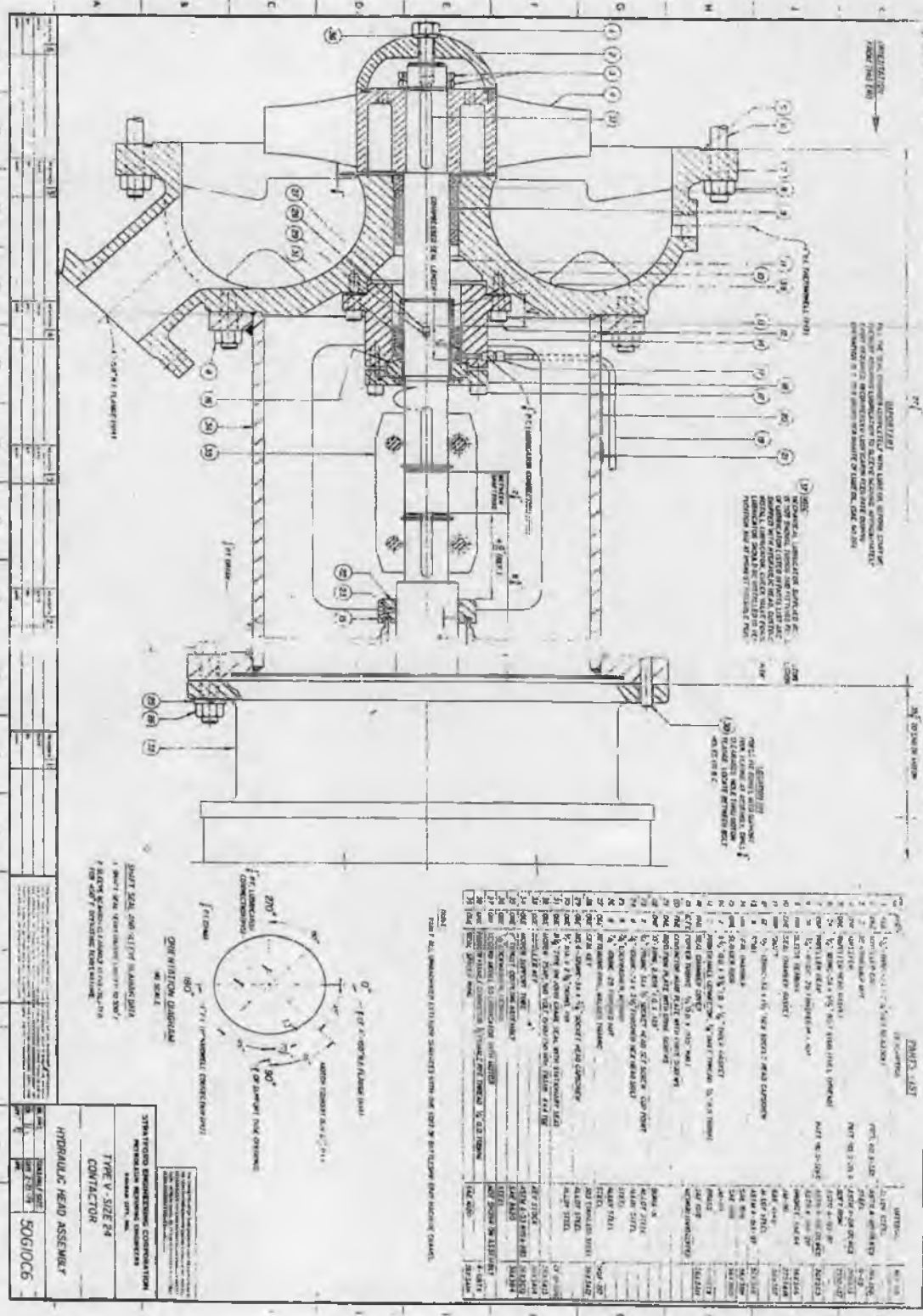

cool down
 1/201

③

جدد الصور
V 201

5

DRAWING TRANSMITTAL
FORM 31323C



Westinghouse Electric Corporation

CUSTOMER ORDER NO. 588 WESTINGHOUSE G.O. NO. KC-11898 MG FOR APPROVAL FOR CONSTRUCTION OR INSTALLATION

CUSTOMER STRATFORD-GRAHAM ENGRG. CORP. 4520 MADISON AVE KANSAS CITY MO 64111
FOR STRATFORD - GRAHAM ENGRG. SAN JOSE, CAL 95112

MARK OF TAG V SZ 24 HEAD 57Z JOB 50G10

DESCRIPTION ITEM 1 SO # 79C60360

SQUIRREL CAGE WINDING ACTION SFC VOLTS AMPS

FRAME SIZE 75/37.5 WIND 1465/735 FRAME 445TDZ NEMA DESIGN U

PHASE 3 SPEED 50 SFC 380 FLA 104/84

INSULATION F F WINDING 40% SFC 1.15 LRA 727/434

INSV AIR WIND SFC FLANGE D KEEL YES NO DUTY 24-HOURS

TEMP PROOF TENV TPC AIR WIND OTHER

TEMP PROOF TENV TPC AIR WIND OTHER

SPACE HEATERS none VOLTS WATTS

INTERNAL PROTECTION none

ADDITIONAL FEATURES



Westinghouse Electric Corporation
Medium Motor and Gearing Division
Buffalo, New York, U.S.A. 14240

Instruction Leaflet
2930-11TE

Page 1

ميد اى موتور
V 201

7

May, 1978
Supersedes I.L. 2930-11TD
dated July, 1976

Installation and Maintenance Instructions
For Life-Line T Motor, Frames 143T-449T

Medium Ac Motors

Receiving

1. Check Nameplate Data.
2. Turn shaft by hand to check that it turns freely.
3. Request "Receiving and Storage Instructions" for long-term storage indoors or any storage outdoors.
4. Lifting eyebolts are designed for raising the motor alone and should be removed after installing motor.

WARNING: The following safety precautions must be observed:

1. Electric rotating machinery and high voltage can cause serious or fatal injury if improperly installed, operated or maintained. Responsible personnel should be familiarized with NEMA MG2, safety standards for construction and guide for selection, installation and use of electric motors and generators, national electric code and all local safety requirements.
2. When servicing, all power sources to the motor and to the accessory devices should be de-energized and disconnected and all rotating parts should be at standstill.
3. Lifting means, when supplied, are intended for lifting the motor only. When two lifting devices are supplied with the motor a dual chain must be used.
4. Suitable protection must be used when working near machinery with high noise levels.
5. Safeguard or protective devices must not be by-passed or rendered inoperative.
6. The frame of this machine must be grounded in accordance with the National Electrical Code and applicable local codes.
7. Avoid contact with start or run capacitors in single-phase motors until a safe discharge procedure has been followed.
8. A suitable enclosure should be provided to prevent access to the motor by other than authorized personnel. Extra caution should be observed around motors that are automatically controlled or have automatic re-setting relays as they may restart unexpectedly.

9. Enclose all belts to prevent injury from broken belts.

10. Shaft key must be fully captive before motor is started.

11. Provide proper safeguards for personnel against possible failure of motor-mounted brake, particularly on applications involving over-hauling loads.

Location

1. Drip-proof motors are intended for use where atmosphere is relatively clean, dry, and non-corrosive. Keep windings clean with a soft brush, cloth or suction.

2. Totally enclosed motors may be installed where dirt, moisture and corrosion are present, or in outdoor locations. The drain plug in the end bracket must be removed periodically to drain accumulated condensation.

3. Explosion-proof motors are built for use in hazardous locations as indicated by Underwriters' label on the motor.

NOTE: In all cases, no surrounding structure should obstruct normal flow of ventilating air through or over the motor.

Installation

Fasten securely to a flat base with maximum size bolts. All ball or roller bearing normal thrust motors may be mounted in any position. Do not drive sheaves, couplings, sprockets or pinions on motor shaft.

Direct Drive

Align shafts accurately. If reverse rotation is detrimental to the driven device check rotation BEFORE connecting the motor to the load. See "start up."

V-Belt Drive

1. Mount motor sheave close to bearing housing.
2. Allow sufficient clearance for rotor end play.
3. Sheave diameter should not be less than NEMA recommended value. See NEMA MG1-14.42.

4. Align sheaves carefully, tighten belts only enough to prevent slippage.

Flange Motor

Fits are accurately machined to mate with driven equipment. Mating surfaces must be free of dirt or burrs and solidly engaged. The assembly should turn freely without stressing shaft and bearings from misalignment and thrust.

Electrical Connections

1. Connect motor per nameplate to correct power supply.
2. Install all wiring, fusing and grounding in accordance with National Electrical Code and local requirements.
3. Identify motor auxiliary devices such as space heaters or temperature sensors. Connect in proper circuits and insulate from motor power cables.

Wound Rotor Motors

a) Connect cables from secondary control to brushholder assembly. Bring cables through squeeze connector on front bracket, where provided.

b) Slip rings must be maintained smooth and true. Machine to restore proper surface for brushes.

c) Brushes must make good contact with slip rings along the whole face of brush. If needed, grind brushes in with fine sandpaper. Do not use lubricants. Service ports are provided for inspection of slip rings and brushes. Spring pressure is preset at about 1 lb. on 215-286T frames and 4 lbs. on 324-449T frames.

d) Must use same grade of brushes.

NOTE: Continuous light load operation can develop "threading" (fling grooving). Different brush grade may be required. Contact factory.

5061

مدل موتور
V201

8

Medium Ac Motors Renewal Parts



Ordering Information
 Motor Order Slip for Motor parts and Parts
 For Motor Order Slip, see page 100
 1. Motor Order Slip
 2. Motor Order Slip
 3. Motor Order Slip
 4. Motor Order Slip
 Plus 1. Motor Order Slip

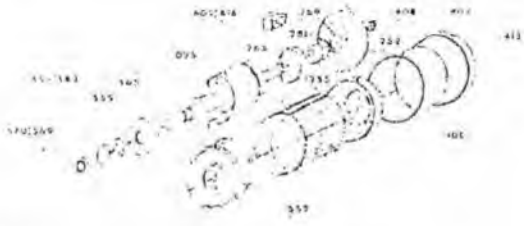

Part No.	Description	1	2	3	4	5	6	7	8
400	Frame	40	54	54	108	150	238	370	416
401	End Bracket	24	24	24	30	24	46	60	80
402	End Bracket	24	24	24	30	24	46	60	80
403	End Bracket	24	24	24	30	24	46	60	80
404	End Bracket	24	24	24	30	24	46	60	80
405	End Bracket	24	24	24	30	24	46	60	80
406	End Bracket	24	24	24	30	24	46	60	80
407	End Bracket	24	24	24	30	24	46	60	80
408	End Bracket	24	24	24	30	24	46	60	80
409	End Bracket	24	24	24	30	24	46	60	80
410	End Bracket	24	24	24	30	24	46	60	80
411	End Bracket	24	24	24	30	24	46	60	80
412	End Bracket	24	24	24	30	24	46	60	80
413	End Bracket	24	24	24	30	24	46	60	80
414	End Bracket	24	24	24	30	24	46	60	80
415	End Bracket	24	24	24	30	24	46	60	80
416	End Bracket	24	24	24	30	24	46	60	80
417	End Bracket	24	24	24	30	24	46	60	80
418	End Bracket	24	24	24	30	24	46	60	80
419	End Bracket	24	24	24	30	24	46	60	80
420	End Bracket	24	24	24	30	24	46	60	80

Notes: 1. This drawing is for reference only. 2. For more information, see page 100. 3. For more information, see page 100. 4. For more information, see page 100. 5. For more information, see page 100. 6. For more information, see page 100. 7. For more information, see page 100. 8. For more information, see page 100. 9. For more information, see page 100. 10. For more information, see page 100.

Customer: STRATFORD-GRAHAM ENGRG. CORP. Customer Order No: 588
 Serial Order No: KC-11892 MG Item: 1 Ship Order or State No: 79060360
 Print Size: 445102 Date: 5-8-79

S/S note

British Standard Flameproof Motors - Cage 'E' Range

50 Cycles - 650 Volts Maximum - Temperature Rise 65°C
THREE PHASE - Continuous Maximum Rating

H.P.	Frame	Full Load Speed r.p.m.	Full Load Amps on 400 V	Efficiency			Power Factor			Direct Starting % of Full Load		Star Delta Starting % of Full Load	
				1/1	2/3	3/4	1/1	2/3	3/4	Torque	Current	Torque	Current
20	E256	2920	27.0	89	88	87	81	80	88	230	700	70	230
	E204	1480	27.0	88	88	87	80	89	82	220	750	70	250
	E324	975	28.0	89	89	88	86	84	78	200	700	80	230
	E326	730	29.0	88	87	85	84	80	78	165	650	50	210
25	E284	2920	33.0	89	89	87	81	80	88	220	650	70	210
	E206	1480	34.0	89	89	88	80	89	85	180	650	55	210
	E326	975	35.0	90	89	88	86	81	76	200	700	60	230
	E364	730	35.0	91	91	90	84	83	75	180	650	55	210
30	E286	2920	40.0	89	89	87	81	80	88	220	650	70	210
	E324	1470	39.0	90	90	89	81	80	88	180	650	55	210
	E364	975	39.0	91	91	90	80	86	86	180	700	60	230
	E365	730	42.0	91	91	90	85	83	75	180	650	55	210
40	E324	2940	53.0	89	89	87	81	80	88	220	700	70	220
	E328	1470	52.0	91	91	90	81	80	88	180	650	55	210
	E365	975	52.0	91	91	90	80	86	85	165	650	80	210
	E404	730	54.0	92	91	90	86	84	80	165	620	50	200
50	E326	2940	66.0	89	89	87	82	81	80	220	700	70	220
	E364	1470	67.0	90	90	89	89	88	84	200	600	60	160
	E404	980	66.0	91	91	90	80	89	86	165	650	50	210
	E405	730	68.0	92	91	90	86	84	80	165	620	50	200
60	E365S	2950	77.0	89	88	86	84	83	82	165	750	50	240
	E365	1470	80.0	91	91	90	89	88	85	200	500	80	160
	E405	980	79.0	91	91	90	80	80	87	165	650	50	210
	E444	735	80.0	92	91	90	87	85	81	165	620	50	200
75	E404S	2950	95.0	90	89	86	84	83	82	165	680	50	220
	E404	1480	97.0	91	90	88	82	81	87	165	650	55	210
	E444	980	97.0	91	91	90	81	80	88	185	650	50	210
	E445	735	100.0	92	91	90	87	85	81	165	620	50	200
100	E405S	2950	126.0	91	90	88	84	83	82	165	680	50	220
	E405	1480	127.0	92	92	91	82	80	80	105	650	55	210
	E445	980	130.0	91	91	90	81	80	88	165	650	50	210
	E504	735	133.0	92	91	90	87	86	82	165	620	50	200
125	XE444S	2950	157.0	91	91	88	85	84	83	165	680	50	220
	XE444	1480	159.0	92	92	91	82	81	88	165	650	55	210
	E504	980	159.0	92	92	91	82	81	88	185	650	50	210
	E505	735	166.0	92	91	90	87	86	82	165	620	50	200
150	XE445S	2950	182.0	91	91	89	86	84	83	165	680	50	220
	XE445	1480	189.0	93	92	91	82	81	80	165	650	55	210
	E505	980	191.0	92	92	91	82	81	89	185	650	50	210
175	E504S	2950	215.0	92	91	90	85	84	83	165	680	50	220
	E504	1480	218.0	93	92	91	83	82	80	165	650	50	210
200	E505S	2950	246.0	92	91	90	85	84	83	165	680	50	220
	E505	1480	246.0	93	92	91	84	83	81	165	650	50	210

BROOK MOTORS LIMITED HUDDERSFIELD ENGLAND

Printed in England

3711/10/85

S/S rdg



M.301-3
Issue 1

PERFORMANCE DATA

British Standard Flameproof Motors - Cage 'E' Range

50 Cycles - 650 Volts Maximum - Temperature Rise 65°C
THREE PHASE - Continuous Maximum Rating

H.P.	Frame	Full Load Speed r.p.m.	Full Load Amps on 400 V	Efficiency			Power Factor			Direct Starting % of Full Load		Star Delta Starting % of Full Load	
				1/1	1/2	1/3	1/1	1/2	1/3	Torque	Current	Torque	Current
1	E162	950	1.15	70	68	63	67	59	47	220	480		
	E164	700	1.4	67	66	58	57	50	40	200	450		
3	E184	950	1.6	73	71	66	70	62	49	220	480		
	E182	710	2.0	75	73	68	54	45	34	240	400		
1	E162	1410	1.95	70	66	60	79	74	63	240	500		
	E182	950	2.1	75	75	69	68	61	51	220	450		
	E184	710	2.4	72	72	63	62	53	45	200	400		
1 1/2	E162	2840	2.6	75	74	69	84	75	64	300	650		
	E164	1410	2.7	73	71	57	82	77	66	240	550		
2	E164	2840	3.4	75	74	69	85	77	66	300	650		
	E182	1440	3.5	80	79	75	78	70	57	250	650		
	E184	950	3.8	78	78	76	73	65	56	220	500		
	E213	720	3.8	83	82	75	68	60	45	180	550		
3	E182	2880	4.3	83	82	78	90	87	77	230	700	70	230
	E184	1440	4.8	83	82	79	81	74	62	250	650	80	210
	E213	950	5.3	81	80	76	75	67	53	200	550	60	180
	E215	720	5.2	83	83	75	75	68	53	200	580	65	150
5	E184	2880	7.2	83	82	79	90	87	77	230	700	70	230
	E213	1440	7.7	85	84	83	82	79	72	210	620	65	200
	E215	960	8.4	84	81	78	76	72	50	200	550	65	180
	E254	720	8.4	84	84	82	76	71	60	170	500	50	150
7 1/2	E213	2900	10.5	86	85	82	90	89	84	230	700	70	230
	E215	1440	11.3	85	84	83	84	79	72	200	620	60	200
	E254	960	12.5	85	85	83	78	71	58	165	600	55	190
	E258	720	12.2	85	85	83	76	71	60	175	550	50	170
10	E215	2900	13.5	87	86	83	91	88	80	230	700	70	230
	E254	1440	14.2	88	86	85	88	86	81	200	650	60	210
	E258	960	15.3	87	85	83	83	78	68	210	700	65	220
	E284	725	16.2	86	86	84	77	71	60	175	550	55	170
12 1/2	E284	950	18.2	88	88	87	85	83	78	165	600	50	200
	E286	730	19.6	87	86	85	79	74	62	185	600	50	190
15	E254	2920	20.0	89	88	87	91		88	230	650	70	210
	E258	1450	21.0	87	87	86	88		81	200	550	60	210
	E286	970	21.0	89	89	88	86		74	170	620	55	200
	E324	730	23.0	87	86	83	80		64	165	600	50	200

القوة
التي
تنتج
من
المحرك
تكون
من
نوع
التي
تنتج
من
المحرك
من
نوع
التي
تنتج
من
المحرك

The ministry of industries and minerals

Hydraulic industries state co.

Advertising

Investment opportunity (partnership contract) 1/2017

CONTRACT OF PRODUCTION LINE FOR THE WELDING ELECTRODES

Based on general companies law no.(22) in 1997 ,article(15) , paragraph(third) and according to the resolution of Iraqi council of ministers (492) in 2013 .

The Hydraulic industries state co. (one of the companies of ministry of industries and minerals) invites all the Iraqi ,Arabic and foreign companies for the competition in the investment opportunity .

- Those ,who wish to participant welcome to visit the company in Baghdad AL Saydia / beside Al Dora bridge to submit their complete offers according to the conditions and technical specifications available in the commercial dep. obverse amount (250,000)ID(not refundable) and offers shall be deposited in the tender box in the location of the company in date (27/8/2017) Sunday at 12: 00 BM maximum . if there a holiday in the intended day the submission delay to the next day
- The participants should attend the conference to answer about all the questions in Sunday (20/8/2017) at (10:00) AM in the location of the company . to more information contact us to the following email .

WWW.industry.gov.iq

E-mail 1: hydraulic.iraq@gmail.com

E-mail 2 : hydraulic.industries1@gmail.com

E-mail 3: hydraulic.industries.p@gmail.com

General manager

TALAL HUSSAIN SALMAN



ANNOUNCEMENT EXTENSION

The State Company for Glass & Refractories Industry (SCG&R) one of the Ministry of Industry and Minerals (MIM) has pleasure to announce its following investment opportunity as (sharing in management and production) according to Investment Iraqi Law (No.22 of 1997 article 15 / III) to moderate .increasing capacities, quality improvement for High Alumina Refractory Factory

Announcement Target

(SCG&R) aims by participating with manufacturers and producers of above products in factories management and production to rehabilitate and increase the production capacities through this valuable opportunities to meet the Iraqi market needs and economic feasibility and benefits accruing to the investor, exploit the availability of raw materials which used in production at good prices improving National product quality. Investors are requested to obtain a copy of investment files against a sum of ID 250,000 (Two Hundred Fifty Thousand Iraqi dinar) not refundable for each file, in addition our company ready to assist the investors with additional detailed information and take necessary arrangements to facilitate site visits to the factories . the investors must submit bids in accordance with the conditions contained in the investment file and will focus on the technical proposal , developmental and financial efficiency. The winner company shall bear all announcement charges, offers should be submitted no later than the end of working hours on Monday 7/08/2017 instead of 16/07/2017), for any urgent explanation through company e-mail address glass19612002@yahoo.com

Eng. Riyadh A Jasim
General Director

وزارة الدفاع
المديرية العامة للعقود والمبيعات
اعلان مناقصة دولية رقم (٨) لسنة ٢٠١٧
تجهيز عجلة صيانة ونصب طاقم الضخ مع مواد تشغيلية

العدد : ١٩٨٥
التاريخ : ٢٠١٧/١١/١١

الى : السادة

م / مناقصة دولية رقم (٨) لسنة ٢٠١٧ تجهيز عجلة
صيانة ونصب طاقم الضخ مع مواد تشغيلية

يسر وزارة الدفاع / المديرية العامة للعقود والمبيعات بدعوة مقدمي العطاءات المؤهلين و ذوي الخبرة لتقديم عطاءاتهم لتجهيز (عجلة صيانة ونصب طاقم الضخ مع مواد تشغيلية) مع ملاحظة ما يأتي:

١. على مقدمي العطاء المؤهلين والراغبين في الحصول على معلومات اضافية الاتصال بالمديرية العامة للعقود والمبيعات من الساعة (٩٠٠ الى الساعة ١٥٠٠) على الايميل Moddg.Contracts@ucidn.iraqi-mod.org او المـوـابـيـل (٠٧٩٠٢٧٨٣١٣٦) وكما موضحة بالتعليمات لمقدمي العطاءات .
٢. متطلبات التأهيل المطلوبة : تجهيز عجلة صيانة ونصب طاقم الضخ مع مواد تشغيلية .
٣. بإمكان مقدمي العطاء المهتمين شراء وثائق العطاء بعد تقديم طلب تحريري (كتاب رسمي) معنون الى وزارة الدفاع / المديرية العامة للعقود والمبيعات وبعد دفع قيمة البيع للوثائق البالغة (١٠٠٠,٠٠٠ مائة الف دينار) .
٤. يتم تسليم العطاءات الى العنوان الآتي (وزارة الدفاع / بغداد / قرب جسر الجمهورية (المنطقة الدولية) في الموعد المحدد (لغاية الساعة ١٢٠٠ من يوم الاثنين المصادف ٢٠١٧/٩/١١) . العطاءات المتأخرة سوف ترفض وسيتم فتح العطاءات بحضور مقدمي العطاءات او ممثلهم الراغبين بالحضور في العنوان الآتي (وزارة الدفاع / بغداد / قرب جسر الجمهورية (المنطقة الدولية) في الساعة (١٣٠٠) من يوم الاثنين المصادف ٢٠١٧/٩/١١) .
٥. اعلان المناقصة للفترة من يوم الاثنين المصادف ٢٠١٧/٨/١٤ ولغاية الساعة (١٢٠٠) من يوم الاثنين المصادف ٢٠١٧/٩/١١ .
٦. تبلغ الكلفة التخمينية الاجمالية : (١,٠٠٠,٠٠٠) \$ واحد مليون دولار .
٧. المنشأ: عجلة صيانة ونصب طاقم الضخ : ايطاليا , امريكا , بريطانيا
متطلبات الصيانة و المواد التشغيلية : ايطاليا , امريكا , بريطانيا , الصين
٨. فترة التجهيز : (١٨٠) يوم
٩. تقديم التأمينات النهائية على شكل خطاب ضمان حسن تنفيذ للعقد بنسبة (٥%) من قيمة العقد بعد التبليغ بكتاب الاحالة وقبل توقيع العقد وان لا يكون خطاب الضمان مشروط ويدفع حين الطلب صادر من مصرف حكومي او مصرف معتمد لدى البنك المركزي العراقي بالنسبة للشركات العراقية والشركات الاجنبية التي لديها تمثيل في العراق ومصرف معتمد لدى المصرف العراقي للتجارة (TBI) بالنسبة للشركات الاجنبية التي ليس لها تمثيل في العراق .

١٠. ان يقدم الطرف الثاني كتاب عدم الممانعة من الاشتراك في المناقصة صادر من الهيئة العامة للضرائب بالنسبة للشركات المحلية والشركات الاجنبية التي لديها تمثيل في العراق على ان يكون معنون الى وزارة الدفاع مع تأييد منحه الهوية الضريبية والرقم الضريبي .
١١. تقديم براءة ذمة صادر من دائرة التقاعد والضمان الاجتماعي للشركات العراقية والشركات الاجنبية التي لديها تمثيل في العراق .
١٢. يتم استيفاء رسم الطابع بنسبة (٠,٠٠٣) ثلاثة بالالف من قيمة العقد وبعملة العقد وفق قانون رسم الطابع رقم (٧١) لسنة ٢٠١٢ ووفقا للاصول والرسم العدلي البالغ (٠,٠٠١) واحد بالالف من قيمة العقد على ان لا يزيد عن (١٠,٠٠٠) عشرة الاف دينار وحسب قانون الرسوم العدلية الرقم (١١) لسنة ٢٠١٥ .
١٣. تقدم الشركات العراقية والاجنبية البيانات المالية لها لآخر سنتين كحد ادنى وتلتزم الشركات العراقية والشركات الاجنبية التي لديها تمثيل في العراق بجلب كتاب من نقابة المحاسبين والمدققين او جمعية المحاسبين يؤيد سلامة الموقف القانوني للمحاسب الذي يقدم الحسابات الختامية ضمن اوراق الشركة لآخر سنتين مالية .
١٤. يعول على السعر المدون كتابية في حالة اختلافه عن السعر المدون رقما كما يعول على سعر الوحدة في حالة عدم صحة مبلغ الفقرة .
١٥. معايير التاهيل :
- أ . عدم الانحراف في توقيتات التجهيز:
- ب. توفر خدمات ما بعد البيع والمواد الاحتياطية للمعدات المقدمة في العطاء .
- ج. سرعة التجهيز .
- د . دقة المواصفات وكفاءة الانتاج .
- هـ . الاسعار التنافسية .
١٦. تلتزم الشركة بتقديم قائمة بالاعمال المماثلة المنجزة معززة بتأييد جهات التعاقد المعنية .
١٧. في حالة تحقق ديون بذمة الطرف الثاني يحق للطرف الاول تحصيل الديون بموجب قانون تحصيل الديون الحكومية العراقي رقم (٥٦) لسنة ١٩٧٧ .
- ١٨ . العقد خاضع لجميع القوانين العراقية النافذة بضمنها قانون ضريبة الدخل المرقم (١١٣) لسنة ١٩٨٢ وتعديلاته وتعليماته .
١٩. يتحمل من ترسو عليه المناقصة اجور النشر والاعلان لآخر اعلان عن المناقصة .
٢٠. لايجوز لمقدم العطاء شطب او حك اي بند من بنود وثائق المناقصة او اجراء اي تعديل عليها .
٢١. في حال اشتراك اكثر من مناقص في تقديم عطاء واحد لتنفيذ العقد تكون مسؤوليتهم تضامنية تكافلية في ذلك لتنفيذه على ان يقدم عقد المشاركة مصادق عليه اصوليا مع العطاء .
٢٢. في حالة الغاء المناقصة فسوف يتم اعادة ثمن شراء الوثائق الخاصة بالمناقصة فقط دون تعويض مقدمي العطاءات .
٢٣. لايجوز لمدير مفوض لاكثر من شركة تقديم اكثر من عطاء واحد في المناقصة الواحدة .
٢٤. يكون موعد انعقاد المؤتمر للاجابة على استفسارات المشاركين في المناقصة الساعة (١٣٠٠) من يوم الاربعاء المصادف (٣٠ / ٨ / ٢٠١٧)

٢٥. ان الدائرة غير ملزمة بقبول اوطا العطاءات .
٢٦. في حالة مصادفة تاريخ الغلق عطلة رسمية فيكون تاريخ التلق اليوم الذي يلي العطلة والذي يكون فيه دوام رسمي .
٢٧. صندوق العطاءات مفتوح طيلة فترة الاعلان وخلال الدوام الرسمي (من الساعة ٩.٠٠ ولغاية الساعة ١٣.٠٠) .
٢٨. في حالة عدم التزام مقدمي العطاءات بما تتطلبه الوثائق القياسية للمناقصة بكافة اقسامها فسيتم استبعاد العطاء .
٢٩. تقوم الشركة بالاطلاع على الوثائق القياسية المرفقة مع المناقصة (٩١) وثيقة باللغة العربية مع ترجمتها باللغة الانكليزية بموجب كتاب وزارة التخطيط العدد: ٢٧١٣١ في ٢٢/١٢/٢٠١٦ واملأ الوثائق المطلوبة وختمها بالختم الحي الخاص بالشركة المقدمة للعطاء مع الوثائق المكونة للعطاء .
٣٠. للمزيد من المعلومات يمكن زيارة الموقع الالكتروني لوزارة الدفاع :

WWW.mod.mil.iq

للاجابة على استفساراتكم مراسلتنا على البريد الالكتروني :

Moddg.Contracts@ucidn.iraqi-mod.org

مكتب المفتش العام :

Nasr.falah@ucidn.iraqi-mod.org

المديرية العامة للعقود والمبيعات

٢٠١٧/١٨/١٨

MINISTRY OF DEFENCE
General Directorate of Contracts and Sales
Advertisement OF International Tender no. 8 / 2017

No.:

Date:

To / Gentlemen

Sub. / INTERNATIOANL TENDER NO. 8 / 2017 supplying vehicle of installation & maintenance of pumping sets with operational items.

(Ministry of Defence of Iraq / General Directorate of Contracts and Sales) are pleased to invite the qualified and experienced bidders to submit their bids to supply (**Vehicle of installation, maintenance of pumping sets with operational items**) and note the following:

1. The qualified bidders who want to obtain additional information shall call General Directorate of Contracts and sales at (900 – 1500) on Moddq.Contracts@ucidn.iraqi-mod.org . Or cell phone: 07902783136 as shown in the instructions to bidders.
2. The requisite qualification requirements (**supplying vehicle of installation, maintenance of pumping sets with operational items**).
3. Interested bidders can buy bid documents , after submitting written request addressed to ministry of defence / general directorate of contracts and sales , after paying amount (100.000) Iraqi dinars
4. The bids are delivered to the following address (Baghdad- karada Merriam near al-Jamhuriya Bridge / entrance of green zone) at the specified date up to (**1200 of Monday ,11th Sep. 2017**) late bids will be rejected, and the bids will be opened by the attendance of the bidders or their representatives at the ABOVE MENTIONED ADDRESS and at time (**1300 of Monday,11th Sep. 2017**).
5. Advertisement's duration shall be **on Monday 14th August 2017 UP TO 1200 of Monday 11th Sep .2017.**
6. The total estimated cost (\$1.000.000), one million UAD.
7. **Wanted country of origin of vehicle : Italy, America, Britain**
Maintenance and installation by:, Italy, America, Britain and china .
8. The supplying period : **180 days**
9. The good performance bond that equals to (**5%**) of the total contract's amount shall be submitted after awarding prior to signing contract .it must be unconditional and payable on request issued by government bank or accredited bank to the central Iraqi bank as for (Iraqi companies and foreign companies hat have representation in Iraq) and a bank accredited by trade bank of Iraq (TBI) as for foreign companies that don't have representation in Iraq.
10. To submit a non – objection letter to participate in tenders issued by General Commission of Taxes as for local companies and foreign that have representation in Iraq addressed to ministry of defence with confirmation of giving taxes identity card and number.
11. Iraqi & representation's bureau of foreign companies in Iraq must submit a letter of discharge issued by Retirement and Social Security Office.
12. To submit stamp's fee (**0.003**) of the contract's amount at the same contract's currency as per act. # 71 of 2012 and (**0.001**) of contract's amount as per judicial fee on condition not to exceed (10.000) Iraqi dinars according to (act # 11 of 2015).
13. Iraqi and foreign companies must submit their financial statements of the last two years at least. Iraqi and foreign companies (which have a bureau of representation) have to submit

a letter issued by Accountants Corporation certifying the legal situation of the accountants who submits the final accounts within the documents of them.

14. Written prices shall be based when differs of digits.
15. Evaluation bases :
 - a –no deviation in supply items
 - b- The quick supplying.
 - c- Accurate specifications and efficiency of production.
 - d-competitive quotations.
16. To submit a list of achieved similar works certified by contracting entities.
17. First party has the right to deduct any debts (if there is any) of second party' payments.
18. Contract shall be subject to all Iraqi valid acts even the Income Taxes Law # 113 of 1982 and its instructions and amendments.
19. The winner shall bear the fees of the last time advertisement.
20. No scrape or amendment in the tender's documents shall be accepted.
21. If many bidders take part in one tender, Their ratified contract's partnership must be submitted
22. If the tender is cancelled by the buyer, the amount of buying the documents of the tender shall be returned to bidders without any compensation.
- 23 Authorized manager of many companies shall be allowed to submit only one proposal.
- 24 The date of holding a meeting to answer companies' inquiries at **1300 of 2017.**
25. Buyer is not obliged to accept the lowest offers
26. If the closing date coincides to be an official holiday, the next day shall be the closing.
27. The tender's box shall be opened during the working hours of the advertisement (**900 up to 1300**).
- 28 OFFERS that don't meet the requirements of the standard bid documents will be refused.
- 29-bidders shall review the standard bid documents of (91) pages in Arabic with translation according to ministry of planning letter # 27131 dated on 22/ 12 / 2016 and fill the required ones.
30. for further information , visit website of ministry of defence

www.mod.mil.iq

To answer your inquiries contact us on:

Moddq.Contracts@ucidn.iraqi-mod.org

For any compliant

Nasr.falah@ucidn.iraqi-mod.org

General Directorate of Contracts and Sales

8/8/ 2017